



How analogy helped create the new science of thermodynamics

John D. Norton¹

Received: 30 June 2021 / Accepted: 18 April 2022

© The Author(s), under exclusive licence to Springer Nature B.V. 2022

Abstract

Sadi Carnot's 1824 *Reflections on the Motive Power of Fire* created the new science of thermodynamics. It succeeded in its audacious goal of finding a very general theory of the efficiency of heat engines, by introducing and exploiting the strange and unexpected notion of a thermodynamically reversible process. The notion is internally contradictory. It requires the states of these processes to be both in unchanging equilibrium, with a perfect balance of driving forces, while also changing. The work of Sadi's father, Lazare Carnot, on the efficiency of ordinary machines provided Sadi with a template of a very general theory of the efficiency of ordinary machines; and a characterization of the most efficient processes in them as those that minimize differences of driving forces and can be run in reverse. Lazare's work could provide these resources because of its choice of a dissipative ontology of inelastic collisions among hard bodies. This historically ill-fated choice meant that Lazare's machines were analogous to Sadi's heat engines in their key aspects: they are built from essentially dissipative processes. Lazare's strategies for controlling dissipation and optimizing his machines were transferrable to the analogous problems Sadi found in heat engines. The unanswerable historical question is whether Sadi would have sought a general theory of heat engines at all or found these general theoretical devices without the template provided in analogy by the prior work of Lazare.

Keywords Caloric · Lazare Carnot · Sadi Carnot · Heat · Machines · Reversible process · Thermodynamics

John D. Norton thanks Rawad El Skaf and Paolo Palmieri for helpful discussion.

✉ John D. Norton
jdnorton@pitt.edu
<http://www.pitt.edu/~jdnorton>

¹ Department of History and Philosophy of Science, University of Pittsburgh, Pittsburgh, PA, USA

1 Introduction

1.1 On the origin of novel ideas in science

This is a paper about the origin of novel idea in science. How did the prominent figures in the history of our science arrive at their greatest ideas? Might the best answer be that these ideas are the products of genius and emerge through a process impenetrable to rational analysis?

This easy answer is, I believe, mistaken. No doubt, some part of the answer will be that a brilliant mind can make connections that no prosaic analysis can dissect. Such moments, opaque to later analysis, time and again prove to be only a smaller part of the discovery. Even the greatest minds have no superhuman powers. They must draw on the resources around them, even if they are able to exploit them better than their peers. I have found repeatedly that the larger process of discovery is one that can be dissected and understood. Einstein founded his special theory of relativity in 1905 with an extraordinary idea concerning time, the relativity of simultaneity. A careful reconstruction (Norton, 2004) of his earlier work shows that years of exploration left it as the only viable option. In the same year, Einstein proposed the revolutionary idea of the light quantum. Similar analysis (Norton, 2006) shows how Einstein's expertise in statistical physics enabled him to see the proposal as encoded in the macroscopic properties of heat radiation.

1.2 Sadi Carnot's *Réflexions*

This paper recounts another story of a great discovery in science and identifies the resources in earlier science that made it possible. Sadi Carnot's *Réflexions sur la Puissance Motrice du Feu* of 1824 is an extraordinary work in science comparable to those of Einstein. Its great contributions are of both facts and methods. First, as to facts, Carnot wrote while the industrial revolution was reaching its zenith. This revolution was powered by heat derived from burning coal. The heat liberated was used to raise steam that would then drive the engines that turned the wheels of industry. Carnot addressed the most practical of problems. Just how much motive power can be derived from some fixed quantity of heat? What design of heat engine is best? Should it employ steam as its operating fluid, or perhaps vapors of alcohol or mercury or sulfur? To these eminently practical questions of industrial economy, Carnot supplied answers of extraordinary generality and simplicity. There is a limit to the motive power that can be generated; and it is set solely by the temperature of the source of the engine's heat and the temperature of the sink to which the spent heat is discharged. The design of a machine that achieves this limit is one whose operation minimizes all unbalanced thermal forces. Achieving this minimum is all that matters for optimizing the efficiency of the heat engine. That optimum is the same, no matter which fluid—steam, alcohol, mercury or sulfur—is used and which design is chosen for the engine.

Carnot could arrive at these extraordinary results because he introduced a new and powerful way of reasoning about thermal systems. It became the foundation of

the new science of “thermodynamics”.¹ The core of his method is the idea of the thermodynamically reversible process. They are processes that are in apparent internal contradiction. They are both always at equilibrium, or infinitesimally removed from it, and also proceed from start to finish, even though equilibrium systems are unchanging.² Comprehending these processes is the great obstacle each student faces in learning to think thermodynamically. It is not so different from the challenge of grasping infinitesimals when learning calculus after the manner of Newton. They are quantities somehow smaller than any non-zero magnitude, but not themselves zero.

1.3 Sadi and Lazare

How did Sadi Carnot arrive at these extraordinary results? This paper seeks to show that Sadi Carnot arrived at key elements of his *Réflexions* through an analogy with the work of his father, Lazare Carnot, on the efficiency of ordinary machines, most notably his 1783, *Essai sur les machines en général*. The connection to his father’s work has long been recognized. In his short biographical note on Sadi, his brother, Hippolyte, remarked vaguely on similarities in various unpublished memoranda by Sadi (H. Carnot, 1897a, p. 36):

I find in them, for my part, touching analogies with the thoughts of my father, although the father and son had, unfortunately, lived almost always apart, by force of circumstances.*³

That Lazare Carnot’s work on machines, specifically, strongly influenced Sadi Carnot’s analysis of heat engines is a guiding theme of the researches into the two Carnots of Charles Gillispie and Raffaele Pisano.⁴ “It appeared to me that Sadi Carnot’s analysis may be read as an application of his father’s invention of the science of machines to heat engines,” Gillispie wrote in his Foreword to Gillispie and Pisano (2014, p. v). Their concluding chapter 11 summarizes the connections between the work of Lazare and Sadi. Their goal is expansive. They seek to collect as many commonalities as they can. What results is eight tables of commonalities of the same type. Each table in turn lists numerous individual commonalities. This will satisfy readers who seek an account of uncompromising thoroughness and attention to every detail. A more casual reader, however, will be rapidly overwhelmed; and a slightly more dedicated reader will struggle to separate the many insignificant commonalities from the few of importance.

¹ So named later through the adjective “thermo-dynamic” by Thomson (1852).

² See Norton (2016) for an examination and historical survey of the concept that I call “The Impossible Process,” the thermodynamically reversible process.

³ Hippolyte’s footnote: “See the Appendix for these memoranda and for other previously unpublished matter.”

⁴ Gillispie and Pisano (2014) are unable to identify much opportunity for collaboration in person by Lazare and Sadi on the latter’s work on heat engines. They note (p. 77) merely a visit of “a few weeks in 1821” by Sadi with Lazare. After that, however, Sadi concentrated on his work on heat engines.

1.4 The heuristic analogies

My goal here is narrower. It is to provide a simplified account of the connection between the work of the two Carnots and to identify what in that connection was of the greatest importance in the novelty of Sadi's work. In my view, there are two extraordinary elements in Sadi's *Réflexions* and we can identify sources for both in Lazare's *Essai*.

First, it is simply extraordinary that Sadi would even seek, let alone find, a general theory of such simplicity for complicated devices like steam engines, which are composed of so many disparate parts. Here Sadi could take his orientation directly from Lazare's work. The explicit goal of Lazare's *Essai* is just such a theory for ordinary machines that transmit motive power, no matter which of many possible components of diverse character are combined in the machines. Sadi sought the same for heat engines.

Second, Sadi's analysis depended on the internally contradictory notion of a thermodynamically reversible process. Here a fortuitous element of Lazare's analysis proved suggestive. Lazare's analysis took its basic process to be the dissipative, inelastic collisions of hard bodies. In them *vis viva*—the forerunner of the modern notion of kinetic energy—is destroyed. His analysis is unlike the foundational studies in mechanics of the ensuing century in which elastic collisions and energy conservation are taken as fundamental. Yet just this ill-fated, dissipative foundation was precisely what made it valuable as a model for Sadi's work on heat engines. For the thermal processes of heat engines are also dissipative, but in another way. In later terms unknown to Sadi, thermal processes only advance if they are increasing the overall entropy of the system in a unidirectional process.

Working within his dissipative ontology, Lazare developed concepts and methods that identified those processes that minimize dissipation and optimize the efficient transfer of motive power in machines. He concluded that the greatest efficiency is found in processes that minimize or eliminate shocks or percussions in the collisions of the bodies; and such processes are realized by what he called "geometrical movements." These last movements are characterized by their reversibility: they can proceed with equal facility in either forward or reverse direction.

At a suitable level of abstraction, the analyses of the thermal and mechanical systems can be the same, since they both implement dissipative processes. When imbalances in driving forces—mechanical or thermal—are minimized, we have processes that are least dissipative. That they are so is suggested by the fact that the minimization of the imbalances is realized in processes that are reversible. That means that we can fully restore the initial conditions merely by reversing the process, so that nothing is lost in the processes that cannot be recovered.

Both of these notions reappear as foundational in Sadi's work. They form the basis of his conception of the thermodynamically reversible process. Where Lazare sought the elimination of the transmission of motive power by discontinuous shocks and percussions, Sadi sought the elimination of all heat transfer by discontinuities of temperature. Where Lazare's geometrical movements were reversible, so also were Sadi's least dissipative process in which heat is always transferred by insensible differences

in temperature. The reversibility of these processes is key to Sadi's whole account. They provide him the means to prove his most general results on the efficiency heat engines.

That Sadi could conceive this notion of a thermodynamically reversible process seems in retrospect astonishing. For such processes, if understood literally, must meet contradictory demands and that makes them inadmissible in any cogent analysis. We are to suppose processes that are always at equilibrium, or at infinitesimal remove, yet at the same time undergoing change. Nonetheless, they become the central conception of a new style of analysis, thermodynamic reasoning.

If, however, we see Sadi as proceeding by analogy with the work of Lazare, it is less astonishing. While we may suspect that imbalanced thermal forces are dissipative, it is hardly obvious that eliminating these imbalances is the necessary and sufficient condition for minimal dissipation in a heat engine. In ordinary machines, however, it takes no special insight to realize that a percussive impact in mechanics is dissipative. For part of the motion in a percussive impact is lost and that loss is manifested in the noise of the impact. The loss is all too evident to anyone who witnesses it. It is not so great a step from that observation to the general demonstration that the elimination of all percussion gives us the most efficient machines.

Lazare's general demonstration for ordinary machines provides a template for the theoretical identification of the least dissipative systems. If Sadi suspects by analogy that that imbalanced thermal forces are the source of dissipation in heat engines, can he close the gap and find a general demonstration that it is so? Should he even suspect that it is so? Lazare's general demonstration in the case of ordinary machines provides the encouragement and the means to close the gap quickly. All Sadi needs to do is to reconstitute Lazare's reversible "geometrical movements" as the analogous reversible processes in thermodynamics and he has all the means needed to show that these reversible thermal processes are the least dissipative.

1.5 The sections of this paper

Section 2 below provides a summary of Lazare's work in his 1783 *Essai sur les machines en général* that pays special attention to aspects that are analogous to those of Sadi's *Réflexions*. Lazare's *Essai* appears clearly written on a superficial scan. However closer reading finds it poorly organized and obscure on point after point. My hope is that, in so far as my own understanding is able, the summary of this section will make the *Essai* sufficiently accessible to readers interested in comparing it with Sadi's later work, without the need to consult the lengthier and more detailed analysis of Gillispie and Pisano (2014). Some readers will find it convenient to skip ahead to Sect. 3, which contains a short synopsis of the major points that enter into analogies with Sadi's later work.

Sections 4, 5 and 6 recount those aspects of Sadi's work that have been widely recognized already as conditioned by the historical context of his work. Section 5 reviews the most important of Sadi's general results, which are derived by what I call his "core reversibility argument." That he worked with the conserved fluid caloric theory of heat (as recalled in Sect. 4) enabled Sadi to arrive at these results without positing

a new second law of thermodynamics or even a strict law of energy conservation. He merely needed the prohibition of perpetual motion. Section 6 reports the analogy Sadi drew between waterwheels and his abstract characterization of heat engines. It also connects Sadi's work with earlier work on ordinary machines such as his father's.

Section 7 recounts the first major analogy in Sadi's *Réflexions* to Lazare's *Essai*. It is that Sadi like Lazare is seeking a very general theory. That now seems less remarkable since we now have the thermodynamics that grew from Sadi's analysis. However, a comparison with other work on steam engines in Sadi's time shows just how far this other work was from conceiving anything like the general theory Sadi offered. Section 8 raises the possibility that Sadi might have even conceived his analysis not merely as proceeding in analogy with that of Lazare's, but as an application of Lazare's general results to heat engines.

Section 9 reviews the analogy between the most efficient processes of Lazare's analysis of ordinary machines and the corresponding reversible processes in Sadi's analysis of heat engines. The analogy could provide Sadi an easy path to his conception, for it is otherwise not obvious that the most efficient processes in heat engines would be those that minimize temperature differences and can be reversed. The analogy may also have encouraged Sadi to proceed with the notion of thermodynamically reversible processes, even though, read literally, they must meet contradictory demands. For Lazare's conception could be implemented without such contradictions.

Section 10 examines the analogy as an argument form, from the perspective of the material theory of induction. The analogy proves to be quite robust and is left intact even if we alter either Lazare's or Sadi's analyses. That indicates that the analogy depends not on some accidental similarity but is grounded quite deeply in the fact that both analyses are treating essentially dissipative processes. Section 11 offers a brief summary conclusion. Two appendices provide technical details that supplement the account of Lazare's *Essai* in Sect. 2.

2 Lazare Carnot's *Essai*

Lazare Carnot presented his analysis of the efficiency of machines his 1783, *Essai sur les machines en général*. Its importance was eventually recognized by the British scientific community. An English translation was published in *Philosophical Magazine* as "Essay upon Machines in General," Carnot (1808, 1809). Lazare himself presented a version of the analysis in his later *Principes fondamentaux de l'équilibre et du mouvement*⁵ (Carnot, 1803). Here I will consider the *Essai*, since I find it most accessible. For an extended account of the research and publications leading up to and after the *Essai*, see Gillispie and Pisano (2014, Chapters 2, 3); and for a shorter account Koetsier (2007).

⁵ Koetsier (2007, p. 31) "The book does not contain anything new compared to the early version...".

2.1 The generality of “machines in general”

The term “machine” now has a general and diffuse meaning. In Lazare’s time, however, the term still retained much of its original meaning. The Diderot *Encyclopédie* was the authoritative source in Lazare’s time. The entry for “Machine” (Diderot, 1765, pp. 795–96) recalled the general conception as concerning devices that augmented and regulated moving forces. It listed the six classic “simple machines”: the lever, the winch, the pulley, the inclined plane, the wedge and the screw. “Composite machines” were just combinations of these simple machines. The entry quickly went beyond this classical conception and recounted many more devices called machines, including hydraulic machines that use pumps to move water. Lazare’s conception followed this more expansive approach. His definition was (1808, p. 157):

When one body acts upon another, it is always immediately, or by the agency of some intermediate body: This intermediate body is generally what is called a machine...

Lazare’s applications later in his *Essai* include hydraulic and pneumatic machines. In all these forms, the central conception is of the passage of motive power.

The goal of Lazare’s analysis was to determine the conditions under which a machine passes motive power most efficiently. The qualification “in general” in the *Essai*’s title is no idle decoration, but conveys the core goal (1808, p. 12):

In my opinion, however, too little attention has been bestowed in the development of those properties which are common to machinery in general, and which for this reason no more belong to the cords of a machine than to the lever, the vice, or any other machine, whether simple or compound.

Lazare sought results of the greatest generality, applicable to all machines as he conceived them.

2.2 Hard body collisions are fundamental

Having set himself the task of finding general results applicable to all machines, Lazare needed a theoretical setting in which such results could be developed. To this end, Lazare took as his starting point the collision of “hard” bodies; or—as we would now call them—inelastic bodies. Lazare mentions bodies of “different degrees of elasticity.” They are to be accommodated as a special case of a system of hard bodies (1808, p. 209):

... we regard the elastic bodies as composed of an infinity of hard corpuscles separated by small compressible rods, to which we attribute all the elastic virtue of these bodies; so that, properly speaking, we do not consider in nature any other than bodies endowed with different moving forces. We shall follow this method as the simplest; we shall therefore reduce the question to the investigation of the laws observed by hard bodies, and shall afterwards make some applications of them to cases in which bodies are endowed with different of degrees of elasticity.

This decision at the outset to base his account on the collision of hard bodies proved decisive for the utility of Lazare's account to Sadi's later reflections on heat engines. Such collisions are essentially dissipative. As we shall see, they inevitably destroy *vis viva*, the earlier version of what we now identify as kinetic energy. The processes of Sadi's heat engines are fundamentally dissipative. Thus, he could find in Lazare's analysis of ordinary machines a model for how one can analyze the efficiency of the operation of processes in dissipative systems.

Had Lazare chosen the collision of elastic bodies as fundamental, his account would have not provided this fertile model for Sadi. While Lazare's choice was fortuitous for Sadi, it all but guaranteed that Lazare's research program would be a dead end. For the statistical mechanics of the following century took conservative physical systems as fundamental. The kinetic theory of gases of Clausius, Maxwell and Boltzmann accounted for gases as collections of rapidly moving molecules undergoing elastic collisions. Had they followed Lazare's lead and treated the collisions amongst molecules as inelastic, successive collisions would deplete the gas molecules of their *vis viva*. It would be impossible to account for the stability and persistence of isolated of gases. Such a kinetic gases would lose their gaseous character when their molecules' *vis viva* was lost.

These considerations do suggest, however, why Lazare's choice of hard collisions was all but unavoidable in his time. Had he taken bodies undergoing fully elastic collisions as his starting point, he would have found it very difficult to recover any distinction between dissipative and non-dissipative interactions. For both momentum and kinetic energy, to use the modern terms, are conserved in such systems. We too easily forget how difficult it was for the modern treatments to recover a precise account of dissipation for such systems. The key device is that dissipation derives from the energy of one component system being distributed over very many degrees of freedom of the larger system. The kinetic energy of two large bodies undergoing an inelastic collision is not destroyed but is dissipated as the chaotic motions of the very many air molecules in the surrounding medium. This dissipative process is too complicated to be treated exactly by such methods as Lazare used. Instead, Maxwell's later innovation was to treat the processes statistically.

Lazare was certainly aware that it would be difficult to separate dissipative and non-dissipative interactions in an ontology of perfectly elastic collision where all interactions are conservative. He remarked in passing (1808, p. 156) on "...the preservation of living powers under the shock of perfectly elastic bodies." By basing his analysis on hard body collisions, he had chosen a fundamental process that is, in general, dissipative. He could then investigate the conditions under which the dissipation would be minimized.

We may also ask why Lazare chose hard body collisions as the fundamental dissipative process. Friction would seem to be the obvious obstacle to machines efficiently passing on motive power. The extra effort needed to overcome friction is evident to anyone who has even slight experience with simple machines like the pulley, wedge or screw. Urging as a general matter than all friction is to be minimized would seem to be a quite serviceable general guide to the minimization of dissipation. Yet friction is all but never addressed directly in Lazare's analysis. The most sustained mention

is an admonition to avoid friction, delivered as something of a practical aside beneath the generality of Lazare's theorems (1808, p. 301):

It is not less evident, that in order to give the machines the greatest effect possible, we should avoid or diminish, at least as much as possible, the powers, such as friction, rubbing of cords, the resistance of the air, which are always, in whatever direction the machine moves, among the number of the forces I have called resisting...

This neglect does not derive from any lack of interest or attention to friction. We learn from the narrative of Gillispie and Pisano (2014, Chapter 3) that Lazare had written two memoirs in 1778 and 1780. In them, he developed ideas that would appear in the 1783 *Essai*. They include discussion of Lazare's experimental work on friction. The two memoirs were written in response to a prize competition announced by the *Académie des sciences* in 1777 on the subject of⁶:

The theory of simple machines with regard to friction and the stiffness of cordage, but it [the Academy] requires that the laws of friction and the examination of the effects resulting from stiffness in cordage be determined by new experiments conducted on a large scale.

Why not treat friction as fundamental? Perhaps, adhering to a corpuscular ontology, the treatment of bodies as collections of hard bodies appeared more fundamental. Friction, we might imagine, would be recovered as a secondary process, arising from the interactions of these corpuscles. Further, the physics of the collisions of bodies was, conveniently, already well developed, whereas theories of friction were still developing. The work that eventually won the Academy prize, Coulomb's (1782) memoir, became a pivotal work on the physics of friction.

2.3 Resolving hard body collisions

The dynamics of machines in Lazare's analysis derive from the inelastic collisions of hard bodies. To enable an analysis of these collisions, Lazare announced two laws. The second characterized a hard body collision (1808, p. 203):

SECOND LAW. —When two hard bodies act upon each other, by shock or pressure, i.e. in virtue of their impenetrability, their relative velocity, immediately after the reciprocal action, is always null.

The simplest case is the collision two hard bodies whose motions are aligned, as shown in Fig. 1. Since their relative speed after the collision is zero (and they must remain in their common line of motion), they stick together.

This law by itself is insufficient to resolve this simple case of aligned motions and, more important, the more general case of collisions of hard bodies whose motions are not aligned, such as is shown in Fig. 2. For this purpose, Lazare needed another law (p. 207):

⁶ As quoted in Gillispie and Pisano (2014, p. 47).

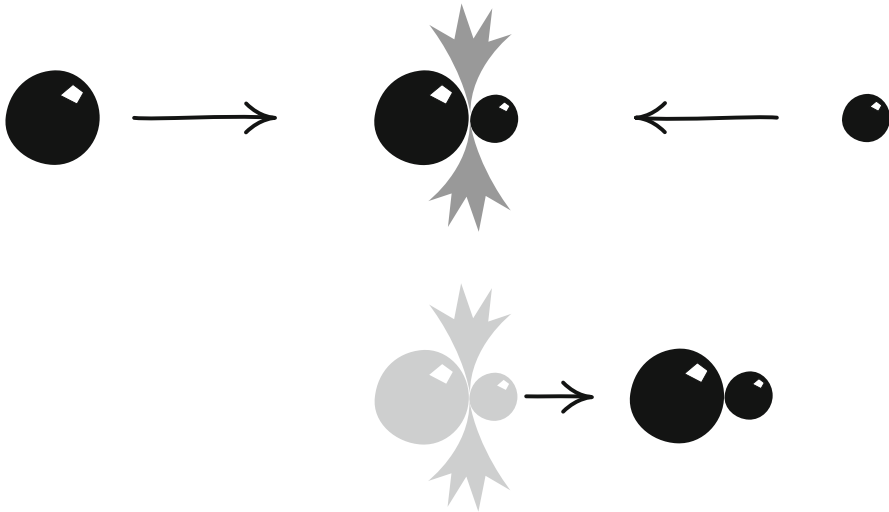

Fig. 1 Hard body collision for aligned motions

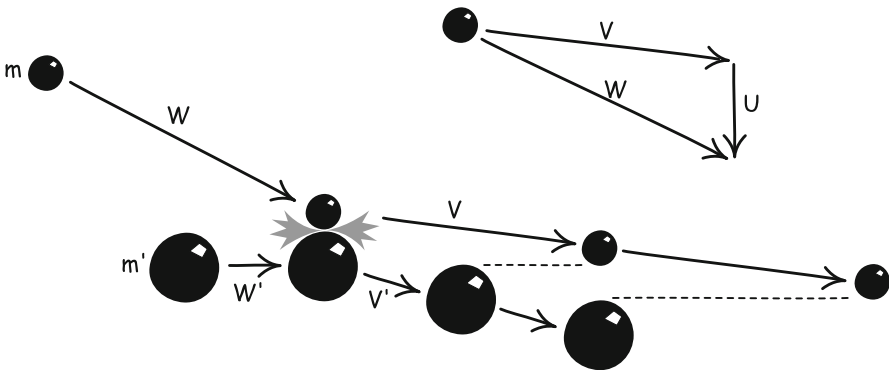

Fig. 2 Hard body collision

FIRST LAW.—Action and Reaction are always equal and contrary.

This is a version of Newton’s own third law. In the ensuing explication, it becomes clear that Lazare’s presentation of the law matched that of Newton in a key aspect. The actions—forces—are treated as impulsive, acting momentarily, and producing a momentary alteration in the motion of the affected bodies. That is, their effect is a discrete change of motion, not a *rate* of change of motion, as is the modern reading. This gives Lazare a rule to be applied directly to a hard body in a collision (p. 208):

... the velocity it assumes the instant afterwards is the force resulting from that which this other body impresses upon it, and from that which it would have without this last force.

The action is measured as the “quantity of motion,” which is the product of the mass and the velocity change. In the collision, according to this first law, the quantity of motion gained by one body is exactly offset by the change in the quantity of motion of the second body. A final stipulation gives Lazare sufficient basis for resolving collisions (p. 209):

That the force or quantity of movement which they exercise upon each other, by the shock, is always directed perpendicularly to their common surface at the point of contact.

Two hard bodies of mass m and m' approach with initial speeds W and W' , collide and recede with final speeds V and V' , as shown in Fig. 2. The speed U shown is described by Lazare (p. 211) as “The velocity which it [the mass] loses in such a manner that W is the result of V and this velocity.”⁷

In Fig. 2, the common surface at the point of contact is oriented horizontally. Since the force of the collision is directed perpendicularly with respect to this surface, the two speeds U and U' are oriented vertically. By Lazare’s second law, their combined effect is that the two bodies have the same vertical speed immediately after the collision. Since no further forces act on the bodies after the collision, this condition persists. Both bodies will have lost all their relative vertical motions. As they recede from the collision, their relative horizontal positions will change, in general, but not their relative vertical positions. This is shown in Fig. 2 by the dashed lines that connect the relative vertical positions of the two bodies at two time intervals after the collision.

The analysis just given applies to two free, spherical bodies colliding. Apparently, we are to suppose that this analysis applies also to two hard bodies that may be connected by an inextensible wire or an incompressible rod through which the force of the hard impact is communicated. This tacit supposition is one of very many unstated presumptions required to make sense of the analysis. This supposition is admissible as long as the analysis is to apply only for the briefest moments before and after the collision.

2.4 Dynamics of machines based on hard bodies

Lazare now turned to apply his methods to a simple model of a machine based on the notion of hard body. That is, he supposed a system (p. 210):

... composed of an infinity of hard corpuscles, separated from each other either by small incompressible rods, or by small inextensible wires...

The task of Section XV, pp. 210–212, was to arrive at the result that forms the basis of his subsequent analysis. The analysis was carried out in two stages. First, he analyzed the hard body collision of two corpuscles, following the set up above. Then he used its result to treat the dynamics of his model machine that consisted of hard corpuscles connected by rods and wires.

⁷ His intent is now much more easily expressed using vectorial concepts. We would now say that the vector velocity \mathbf{W} is the vector sum of the vector velocity \mathbf{V} and the vector velocity \mathbf{U} .

Lazare considered some set of interactions of the corpuscles, such that each corpuscle of mass m ens up with speed V having lost speed U (as defined above), where Z is the angle between the directions of the speeds V and U . Using the symbol s to indicate a summation over all the bodies in the system, he arrived at his “first fundamental equation” (p. 212)⁸:

$$s[\text{um}]m V U \text{ cosine } Z = 0 \quad [\text{Lazare/s equation label}] \quad (\text{E})$$

Lazare’s derivation reads superficially as a full and clear demonstration. A closer reading finds its steps to be incompletely specified to the extent that following its logic is all but impossible, unless the reader can discern substantial missing details.⁹ We are to suppose that the equation applies to the situation in which all bodies in the system interact instantly or in such a brief period that each body only undergoes a single hard collision. This supposition is essential if the results Lazare finds are to apply, for they cease to apply once we concatenate hard collisions over the same bodies. Another important imprecision lies in the expression of results that use summations. The summations extend over different sets of bodies, but the reader is left to guess just which they are in each case. A reconstruction of Lazare’s demonstration, embellished by my best guess over the missing suppositions, is provided in the *Appendix: Lazare’s Demonstration of his “First Fundamental Equation.”*

2.5 Least dissipation from the elimination of percussion

The importance of Lazare’s “first fundamental equation” is not apparent, at least to modern readers; and the sections immediately following Lazare’s section XV are slow to demonstrate its importance. Worse, the obscurity of Lazare’s exposition through omitted suppositions persists, so that I have little hope of reliably reconstructing his derivations. Fortunately, that is unimportant for present purposes, since all that matters is what Lazare claims to have established and that Sadi knows of these claims. Among them is one that has close affinity to a central idea in Sadi’s analysis and can be reliably reconstructed. The result appears as a corollary in Section XXIV (pp. 316–317):

In the shock of hard bodies, whether some of them are fixed, or all moveable, or (what comes to the same thing), whether the shock be immediate, or given by means of any machine without springs, the sum of the active forces before the shock, is always equal to the sum of the active forces after the shock plus the sum of the active forces which would take place if the velocity which remains to each moveable body were equal to that which it has lost in the shock.

Lazare then derives a symbolic expression for this equality from his “first fundamental equation” (E). Recalling the notation used there, W is the speed before the collision of a mass m , V the speed after the collision and U the speed lost in the collision. The

⁸ The ordinary s appears in the English translation of (1808). Lazare’s original text (1783) employs an elongated s , more reminiscent of our modern symbol for integration.

⁹ This difficulty remains even after assistance from the secondary literature of Koetsier (2007) and Gillispie and Pisano (2014, Chapter 2).

speeds are all directed, so they correspond to a displacement in space in some unit of time. It follows that they are related by the geometric rules for directed displacements in space. The rule applicable and used by Lazare is the cosine rule from trigonometry. He writes:

$$W^2 = V^2 + U^2 + 2VU \cos z$$

where z is the angle between the directions of V and U . Lazare multiplies this equality by m and sums over all the masses in the system to arrive at

$$\sum m W^2 = \sum m V^2 + \sum m U^2 + 2 \sum m V U \cos z$$

The last cosine term vanishes according to (E), so that we have the final result:

$$\sum m W^2 = \sum m V^2 + \sum m U^2 \tag{1}$$

These last manipulations are readily reproduced using a later vector notation, as shown in the *Appendix 2: Lazare’s Demonstration of the Conservation of Vis viva*.

The goal of securing the most efficient conveyance of motion is for the speeds after the collision, V , to have captured as much as possible of the speeds prior to the collision, W . Since the three terms in Eq. (1) are the sums of squares, each is positive. Hence, the measure of the conveyed motion, $\sum m V^2$, approaches the measure of the motion available, $\sum m W^2$, if we minimize the measure of the motion lost in the collisions, $\sum m U^2$.

In his specification of the system of Section XV, Lazare had allowed two kinds of motions (pp. 209–210): “...the movement may either change suddenly, or vary by insensible degrees...” We can infer from Eq. (1) that the lost motion U may be minimized by eliminating the first sudden sort of change of motion, the shock or percussion, and employing only the second type, which varies by insensible degrees. To see this, we replace a single collision by many smaller collisions. For simplicity, imagine that it is possible to replace the single collisions represented in (1) by very many— N —collisions in sequence, each with the same smaller speed change $U^* = U/N$. Equation (1) for the collected effect of these N collisions in sequence is

$$\sum m W^2 = \sum m V^2 + N \sum m U^{*2}$$

The final term that measures the motion lost in the collision is

$$N \sum m U^{*2} = N \sum m (U/N)^2 = (1/N) \sum m U^2$$

This final term can be brought as close to zero as we like by choosing N sufficiently large. As N grows arbitrarily large, we approach arbitrarily closely to the case of the full transfer of motion:

$$\sum m W^2 = \sum m V^2$$

In Lazare's time,¹⁰ these quantities are the sums of the "living force" or vis viva of the components. In the English translation above from *Philosophical Magazine* (1808), they are called "active forces." "Living forces" would be a better translation of Lazare's (1783, pp. 48–49) French *forces vives*. The limit approached here is the conservation of vis viva that arises automatically in the case of elastic collisions.

In approaching this limit, the process always consists of discrete, hard body collisions, even if they are a concatenations of arbitrarily many, very small collisions. In approaching this limit, the system is mimicking ever more closely a conservative system whose components interact continuously, without any dissipative shocks. Presumably it is this approach to the conservative limit that Lazare alludes to in his ensuing comment (p. 317):

The analogy of this same equation with the preservation of the active forces in a system of hard bodies the movement of which changes by insensible degrees, is still more evident, since it then regards a case peculiar from that we have examined; it is in fact visibly the particular case where U is infinitely small, and therefore U^2 is infinitely small of the second order; this reduces the equation to $s[\text{um}] mW^2 = s[\text{um}] mV^2$.

This notion that the velocity lost can be made infinitely small recalls the infinitesimals of the calculus, of which Lazare had expert knowledge.¹¹ We shall see this allusion to the infinitesimals of calculus appearing again in Sadi's analysis.

In this protocol for preserving vis viva, we see a basis for one of the major claims Lazare made in his introductory Preface (1808, pp. 11–12):

There will also be found among these reflections one of the most interesting properties of machines, which I think has not yet been remarked; it is, that in order to make them produce the greatest possible effect, it must necessarily that there be no percussion, i.e. that the movement should always change by imperceptible degrees;...

2.6 Geometrical movements

Prior to these result concerning the conservation of vis viva and immediately after the derivation of his "first fundamental equation," Lazare introduced a notion that is, I believe, the template that Sadi used for thermodynamically reversible processes in heat engines. This is the conception of "geometrical movements." They are introduced in Sections XVI and XVII, pp. 212–216). They are, by design, motions that eliminate shocks and thus realize the conservation of vis viva. His definition reads (pp. 212–213).

...if a system of bodies sets out from a given position with an arbitrary movement, but yet of such a nature that it is possible to make it take another in every

¹⁰ Modern readers will, of course, recognize these terms as twice the kinetic energy and that the term $s[\text{um}] mU^2$ is simply twice the kinetic energy lost in the collisions due to their inelasticity.

¹¹ If we take $1/N$, for large N , to represent quantities of the first order of smallness, then the speed $U^* = U/N$ is first order small and the lost vis viva, in a single collision, $s[\text{um}] mU^{*2} = (1/N^2) s[\text{um}] mU^2$ is of the second order of smallness, that is, of the size of quantities of first order small squared.

respect equal and directly opposite, each of these movements will be named a geometrical movement...

Perhaps readers in Lazare's time might have found this definition illuminating. It now seems quite opaque. Fortunately, Lazare appended to the definition a long footnote that explained his intent in greater detail, using many examples.

The simplest example in the footnote concerned two bodies at each end of an inextendible wire. As long as the movement of the bodies is such that the wire remains fully extended, then the motion is geometrical. I imagine Lazare intends a motion of rotation about some center. For any motion that satisfies this condition, there is a movement that exactly reverses the motions, which will then also satisfy the condition that the wire remains fully extended. Since this condition of reversibility is satisfied, the motion is geometrical. In contrast, Lazare considers the case in which the two bodies approach. Then the wire slackens and is no longer fully extended. The reversed motion—that the bodies recede—is not possible since the connecting wire is inextendible. This motion is not geometrical.

The essential idea seems to be that geometric motions are continuous motions that proceed without any percussions or shocks. As a result, Lazare will be able to show that they conserve *vis viva*. We can see in this example why the name “geometrical” is apt. For the trajectories of the bodies (but not their speeds) are determined simply by the geometry of the two bodies and the fully extended connecting wire. This conforms with Lazare's remark in his Preface (p. 9) about “certain movements which I call *geometrical*, because they may be determined by the principle of geometry alone, and are absolutely independent of the rules of dynamics.”¹²

A more interesting example is that of a winch with a large diameter wheel and small diameter cylinder, as shown in Fig. 3. Its axis is oriented horizontally and weights are attached to each with cords that wind around the wheel and the cylinder. A lighter weight is attached to the wheel, while a heavier weight is attached to the cylinder. The machine enables us to raise the heavier weight by lowering the lighter weight, using the larger diameter of the wheel as leverage over the smaller diameter of the cylinder. A geometrical motion arises when we keep both cords taut. We lower the lighter weight through the distance of one wheel circumference. The heavier weight is then raised by the smaller distance of one circumference of the cylinder. This movement is reversible, as required of geometrical movements, since the reversed motion is possible. We could equally have raised the lighter weight attached to the wheel, while the heavier weight attached to the cylinder fell.

As an illustration of a non-geometrical motion that cannot be reversed, Lazare imagined the lighter weight falling through a distance of one wheel circumference, while the heavier weight is induced to rise up a distance greater than the cylinder circumference. Exactly how this could happen is unclear. Perhaps, as shown in Fig. 4, Lazare intended that the lighter weight already had some large initial speed downwards. If the lighter weight's fall is obstructed at the end of its motion, the heavier weight will continue to rise and the connecting cord will go slack. That is, at least my best interpretation of another less than clear passage. Lazare writes (p. 214).

¹² The absolute independence from the rules of dynamics, however, does not seem to be realized.

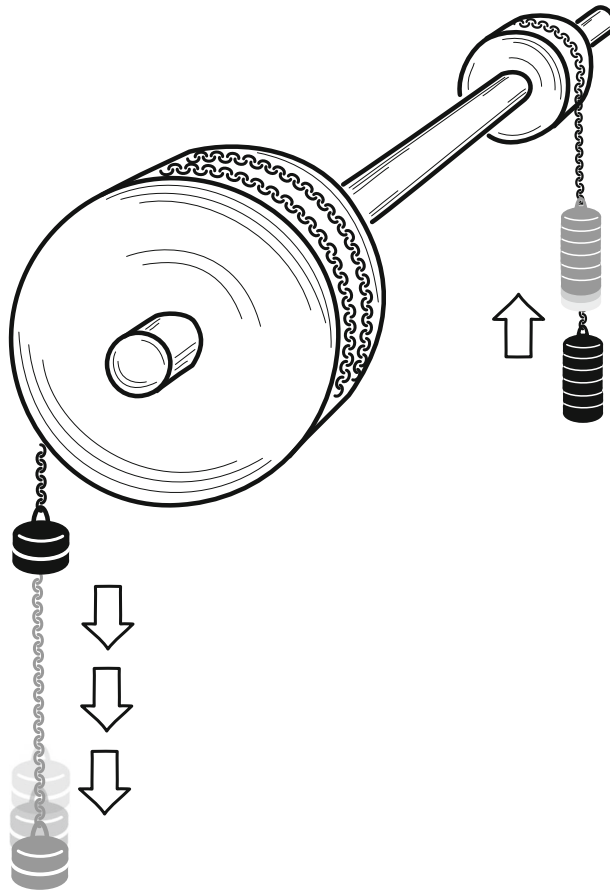

Fig. 3 Geometrical movement of a winch

... but if while we cause the weight attached to the wheel to descend from a height equal to its circumference, we should cause the weight attached to the cylinder to ascend from a height greater than its circumference, the movement would not be *geometrical*, because the equal and contrary movement would be visibly impossible.

I assume that Lazare intends¹³ “the cylinder to ascend *to* a height greater than its [cylinder’s] circumference.”

A further important feature of least dissipative motions manifests here. If the two weights are in exact balance of forces and there is no friction in the bearings or elsewhere, then there is a process that transfers the motive power of the raised lighter

¹³ The obscurity lies in Lazare’s original French, which reads (1783, p.29) “... mais si tandis qu’on fera descendre le poids attaché à la roue d’une hauteur égale à sa circonférence, on faisoit monter le poids attaché au cylindre d’une hauteur plus grande que sa circonférence...”.

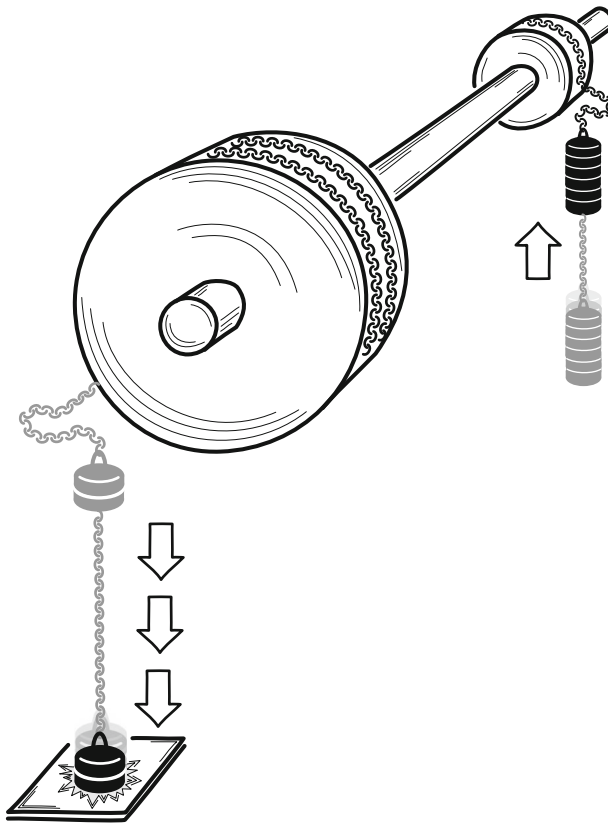

Fig. 4 Non-geometrical movement of a winch

weight to the heavier weight. It is simply the uniform motion of the system at constant speed, even if small. (That this non-dissipative process can be realized if we ignore friction stands in contrast with the corresponding limiting processes of Sadi. These thermal processes would require the simultaneous satisfaction of contradictory conditions.)

2.7 Lazare's hydraulic machines

Later in his *Essai*, Lazare applies his general principles to specific machines. He reprises his practical morals for maximizing efficiency. "... we should avoid every shock or sudden change whatever..." (p. 300). "... in order to make machines produce the greatest possible effect, they must of necessity never change their movement, except by insensible degrees" (pp. 299–300) "we should avoid every sudden change which is not essential to the constitution of the machine." (p. 300).

These principles are applied to hydraulic machines. Here Lazare apparently is considering something like the water wheels that power mills. (p. 300).

In order to make the most perfect hydraulic machine, i.e. capable of producing the greatest possible effect, the true difficulty lies, 1st, In managing so as that the fluid may lose absolutely all its movement by its action upon the machine, or at least that there should only remain precisely the quantity necessary for escaping after its action; 2d, Another difficulty occurs in so far as it loses all this movement by insensible degrees, and without there being any percussion, either on the part of the fluid, or on the part of the solid parts among themselves:...

What now follows is a remark whose analog for heat engines becomes one of the most important of Sadi's results: a few conditions only—the above two—must be met by a hydraulic machine if it is to be the most efficient. All other attributes of the machine are irrelevant to its efficiency. (p. 301).

... the form of the machine would be of little consequence; for a hydraulic machine which will fulfil these two conditions will always produce the greatest possible effect:...

Next, Lazare observes a problem with this specific design of machine. It is contradictory to optimize for both conditions that lead to greatest efficiency. Some balance between efficiency and actual operation has to be found: (p. 301).

... it is impossible to fulfil at once the two conditions most desirable, the more we wish to make the fluid lose of its movement in order to attain the first condition, the stronger will be the shock; the more, on the contrary, we wish to moderate the shock in order to approach the second, the less will the fluid lose of its movement.

This may appear similar to the problem of implementing reversible processes in Sadi's heat engines: they require an unrealizable limit of infinitely slow operation. However, that is not the complication Lazare has identified. In order to minimize shock, Lazare is not concerned that we end up slowing the machine to a halt. Rather Lazare is suggesting just that we minimize shocks by letting the water move through the wheel in some manner without its movement being redirected into that of the wheel. That is, we minimize shocks by diminishing the efficiency of the extraction of motion from the water.

While Lazare's geometrical motions are defined as reversible, there is no direct application of the notion of these reversible, geometric motions to hydraulic machines. Geometrical motions are illustrated in his examples as masses connected by rods and inextendible wires. This model does not seem applicable to a water wheel. The example of the water wheel is immediately followed by that of a hydraulic pump, used to raise water. (p. 301) While we might now think of it as just a water wheel run in reverse, Lazare does *not* characterize it as such. He does *not* make any connection to the reversibility of geometrical movements.

3 What Sadi can find in Lazare's work

This last section is rather densely written in order to convey a sense of relevant aspects of Lazare's project and work. It will be convenient here to collect in terse form those ideas that most closely parallel the innovations of Sadi's later account of heat engines.

- (i) *A simple, universally applicable account of the efficiency of ordinary machines.*

While we can find conditions for optimal performance of any particular machine by adjusting the details of that machine's operation, Lazare tackled all machines that transmit motive power and formulated a simple account of when they are all most efficient in the transmission. The important idea is that such a general theory is possible and achievable. A suggestive application is the waterwheel: if all shocks are avoided, then nothing else matters in the design. Greatest efficiency is achieved by that one condition.

- (ii) *A basic ontology for machines that is dissipative.*

We now default to a basic ontology for machines that is conservative. Dissipative processes like friction are treated as arising from processes that still conserve energy, but just distribute it over many degrees of freedom that make it inaccessible to us. Lazare's most basic process was a hard or inelastic collision ("shock," "percussion") in which (in modern terms) energy is not conserved.

- (iii) *A way to characterize the least dissipative processes in his ontology.*

Ordinary machines in Lazare's dissipative ontology are most efficient in transmitting motive power if all imbalances in driving forces, such as percussions and shocks, are eliminated. All changes must be by insensible degrees. "Geometrical movements," conform with these conditions. They are defined as those that can be reversed.

4 Heat as conserved caloric

Before turning to the analogies that will be the main subject of this paper, here and in the next section, I will review two aspects of Sadi Carnot's work that have come to be widely known. To see the first and its importance, we start by considering how Sadi's project would be approached today. Which are the most efficient heat engines? We now understand a heat engine to be a device that converts heat energy into useful mechanical work. The most efficient engines, we would say if we were to start afresh, are those that convert all their heat energy into work. We now know that such a conception is a poor starting point. A familiar version of the second law of thermodynamics directly asserts its impossibility.

Sadi's general model of heat engines could not employ this approach. He was working before the general notion of energy and its conservation had been established.

He adopted a then dominant view of heat as a conserved fluid, the caloric.¹⁴ This meant that a unit of caloric is indestructible. Whatever caloric is supplied to a heat engine remains unchanged. Each unit of caloric that enters a heat engine must remain inside it or leave it as a unit of caloric. How then can a heat engine generate motive power? Sadi looked to the motion of caloric. Motive power derives from the way that the caloric passes from a higher temperature, such as the boiler of a steam engine, to lower temperature, such as in the condenser of a steam engine.

After Sadi's account had been modified by Clausius and Thomson to accommodate the conversion of heat into work, Sadi's use of the conserved fluid theory of heat was dismissed as an unfortunate aberration. Maxwell (1871, p. 139) wrote of it:

Carnot himself was a believer in the material nature of heat, and was in consequence led to an erroneous statement of the quantities of heat which must enter and leave the engine. As our object is to understand the theory of heat, and not to give an historical account of the theory, we shall avail ourselves of the important step which Carnot made, while we avoid the error into which he fell.

5 Sadi's core reversibility argument

5.1 The argument

Sadi's use of the conserved caloric account of heat was however, a fortuitous error, for it led him directly to the model of heat engines that proved most fertile in the development of thermodynamics. One of its most extraordinary results follows quickly from Sadi's approach: the greatest efficiency of a heat engine is determined solely by the temperatures of the source that supplies the heat and the sink to which the heat is discharged. Without the necessity to discharge heat, the crucial lower temperature sink would not have been an obviously essential element. Moreover, Sadi could then show, nothing else beyond these temperatures matters in determining this greatest efficiency. Whether the machine operates with steam or in any other mode, the greatest efficiency will be the same.

Sadi isolated this core result in italicized text ([1824]1897, p. 55):

... the maximum of motive power resulting from the employment of steam is also the maximum of motive power realizable by any means whatever.

The method of proof of this result in the pages preceding this announcement is one of Sadi's most significant contributions to thermodynamics. He considers thermal processes that can be reversed. He assumes a special heat engine that operates entirely by these reversible processes between two temperatures. Its motive power derives from moving caloric from a hotter heat source to a cooler heat sink. A second instance of this same engine, operated in reverse, is introduced. They are coupled such that the motive power produced by the first engine is consumed by second engine, which uses it to

¹⁴ But see Sect. 8 below for the suggestion that Sadi's adherence to the conservation of caloric was not univocal.

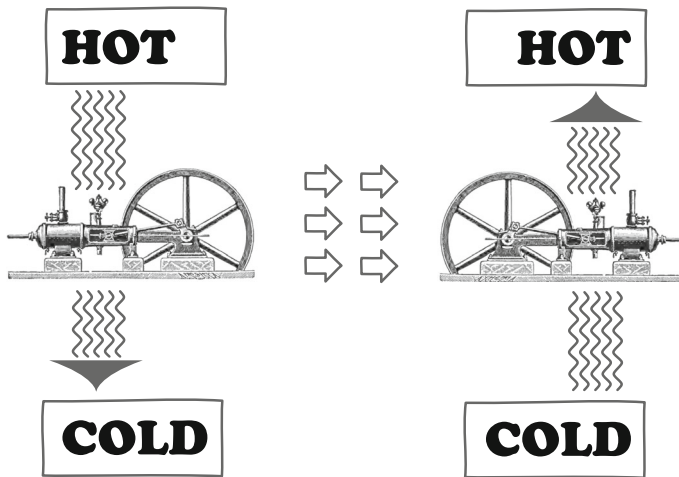

Fig. 5 Two coupled reversible heat engines

return caloric from the cooler heat sink to the hotter heat source. Since its operation is the exact reverse of the first engine, the quantities of motive power and caloric in both engines are the same; what is reversed is the direction in which they move. The first engine moves caloric from hot to cold; the reversed engine from cold to hot. The first engine produces motive power; the reversed engine consumes it. The net effect of the operation of the coupled engines is shown in Fig. 5. All the motive power produced by the first engine—shown as horizontal arrows—is consumed, exactly, by the second; and each unit of caloric drawn from the heat sink is returned to it.

Now comes the moment of startling ingenuity. Suppose for *reductio* that there is a different heat engine of any construction—reversible or not—that could produce more motive power for each unit of caloric moved from hot to cold. We could run the first engine in reverse and couple it to this new engine as before. The reversed engine would return each unit of caloric to the hotter heat source. It would do so consuming *less* motive power than supplied by the new engine. For the new engine by supposition creates *more* motive power for each unit of caloric moved than does the original reversible engine. The overall effect is shown in Fig. 6. All quantities of caloric would be restored to the heat source, but there would be a surplus of motive power, shown as the black, filled arrows. We would have produced motive power without any source.

This, Sadi assured us in most definite terms, is an impossible outcome (p. 55).

... this would be not only perpetual motion, but an unlimited creation of motive power without consumption either of caloric or of any other agent whatever. Such a creation is entirely contrary to ideas now accepted, to the laws of mechanics and of sound physics. It is inadmissible.*

The *reductio* argument is complete. The supposition of a heat engine of greater efficiency than the original reversible engine leads to a contradiction and is falsified. For

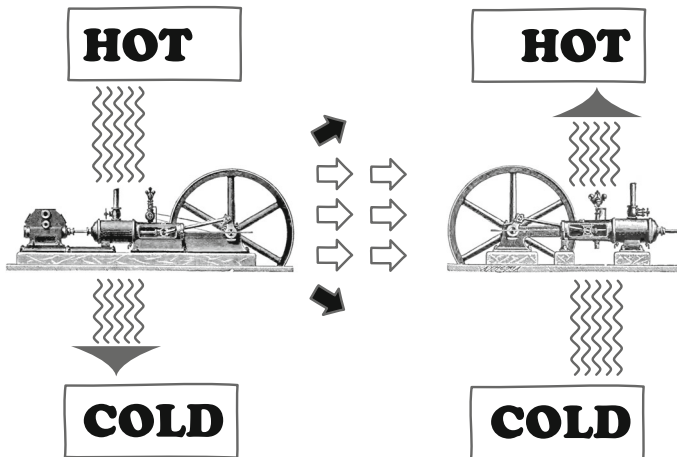

Fig. 6 A heat engine of greater efficiency yields net motive power

fixed temperatures of heat source and sink, all reversible heat engines operate with the same efficiency and they are the most efficient of all heat engines.

This simplest demonstration of Sadi's main result is repeated with greater precision later in his memoir. On pp. 63–67, he instantiates the reversible heat engine with an engine that performs the celebrated Carnot gas cycle.

5.2 Perpetual motion

Sadi's use of the term “perpetual motion” is literal: it simply means a motion that continues indefinitely. It would include the unimpeded inertial motion of a free body. Sadi's footnote at “*” is an extended defense of the impossibility of perpetual motion. As he put it in the footnote, such motion is “a motion that will continue forever without alteration in the bodies set to work to accomplish it.” (p. 237).

We would now include under that term a machine that produces mechanical power without consuming any fuel or depleting any other agency. A version of that later conception is one that Sadi *adds* to the problem of perpetual motion in the text above as a distinct and equally impossible notion. In his footnote, but not the main text, Sadi suggests that we should merge the two conceptions. He wrote (p. 238).

The general and philosophic acceptance of the words *perpetual motion* should include not only a motion susceptible of indefinitely continuing itself after a first impulse received, but the action of an apparatus, of any construction whatever, capable of creating motive power in unlimited quantity, capable of starting from rest all the bodies of nature if they should be found in that condition, of overcoming their inertia; capable, finally, of finding in itself the forces necessary to move the whole universe, to prolong, to accelerate incessantly, its motion. Such would be a veritable creation of motive power.

Here we might note that Lazare's *Essai* (Sect. LXI, pp. 301–302) included an argument against the possibility of perpetual motion based on his analysis. However, it seems unlikely that this portion of Lazare's text was important to Sadi. Lazare's conclusion pertains only to perpetual motion in Sadi's literal sense of a continuing motion. It does not extend to the stronger idea whose dismissal is essential to Sadi's argument: a device that produces motive power without depleting another agency.

While Sadi's argument was framed in terms of caloric, his argument and its result survived the transition to the later thermodynamics in which heat is converted into work. It has been widely noted that Sadi's analysis did not require the positing of the second law of thermodynamics. That came later, when Sadi's analysis was adjusted to allow that heat is converted into work. Then Thomson found that a second, independent law was needed to complete the adjusted analysis. In one version it asserts the necessity of Sadi's model: heat cannot be converted fully into work; a heat engine must always discharge heat to the lower temperature reservoir. What is less commonly noted is that Sadi's analysis did not even need the full content of what became the first law of thermodynamics, the conservation of energy. Sadi's analysis only needs a part of it, that motive power cannot be *created* without depletion of some source. His analysis does not require that motive power cannot be *destroyed*. Such destruction arises in Lazare's hard body collisions, so presumably it would not be beyond Sadi's conception.

6 The waterfall analogy

Having completed his proof, Sadi used an analogy to a waterfall to illustrate his result. Sadi's statement of it in full is ([1824]1897, pp. 60–61, his emphasis):

According to established principles at the present time, we can compare with sufficient accuracy the motive power of heat to that of a waterfall. Each has a maximum that we cannot exceed, whatever may be, on the one hand, the machine which is acted upon by the water, and whatever, on the other hand, the substance acted upon by the heat. The motive power of a waterfall depends on its height and on the quantity of the liquid; the motive power of heat depends also on the quantity of caloric used, and on what may be termed, on what in fact we will call, *the height of its fall*,*¹⁵ that is to say, the difference of temperature of the bodies between which the exchange of caloric is made. In the waterfall the motive power is exactly proportional to the difference of level between the higher and lower reservoirs. In the fall of caloric the motive power undoubtedly increases with the difference of temperature between the warm and the cold bodies; but we do not know whether it is proportional to this difference. We do not know, for example, whether the fall of caloric from 100 to 50 degrees furnishes more or less motive power than the fall of this same caloric from 50 to zero. It is a question which we propose to examine hereafter.

¹⁵ Carnot's footnote: "The matter here dealt with being entirely new, we are obliged to employ expressions not in use as yet, and which perhaps are less clear than is desirable."

The analogy depends on the factual similarity of water and caloric: both are conserved substances that can generate motive power in moving from a higher altitude or temperature to a lower altitude or temperature. The maximum motive power that can be derived from the fall of some volume of water depends only on height through which the water falls and is independent of the design of the machine that extracts it. So analogously, the maximum motive power derived from the motion of caloric from one temperature to another depends only on these temperatures.

While Sadi's text does not describe it, the analogy can be extended to the method of proof Sadi used to establish the results of his core reversibility argument. We imagine a water wheel of some construction that operates by reversible processes in extracting motive power from the falling water. We can run a second instance of this water wheel in reverse that consumes exactly the motive power supplied by the first. As shown in Fig. 7, that second water wheel would return to the higher reservoir exactly the water drawn by the first. Were there any other design of machine that could extract greater motive power from each quantity of water, using it instead of the first water wheel would lead to a surplus of motive power and an impossible perpetual motion machine.

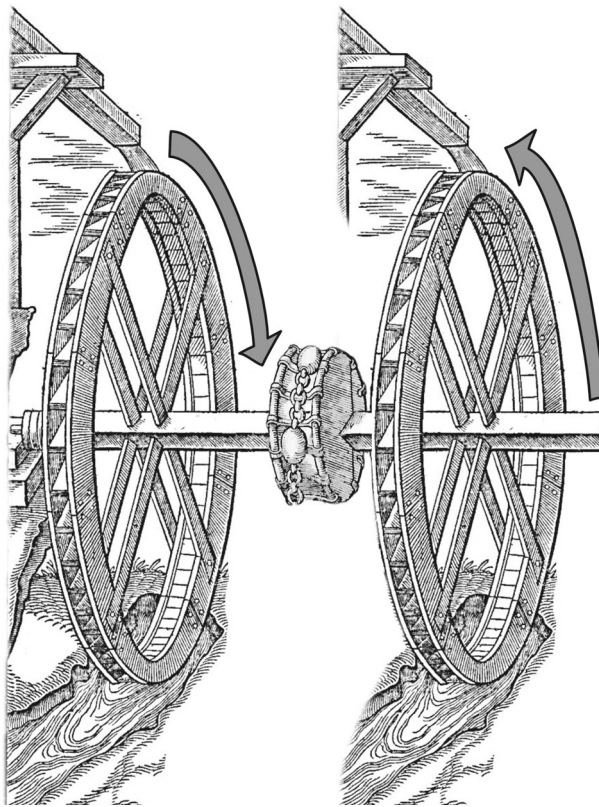

Fig. 7 Coupled water wheels

The fortuitous role of Sadi's use of caloric theory and the suggestive analogy to waterfalls has come to be widely recognized in recent literature. It appears in various version in almost all forms of the present literature, as my hasty and unsystematic survey shows. It is found in histories of thermodynamics, such Müller (2007, p. 53); in recent thermodynamics textbooks, such as Balmer (2011, p. 209); and in popular writings, such Lemons (2019, p. 38).

While this much of Sadi's work is now recognized, two elements of special importance are overlooked. They are my concerns in this paper and are described in the following two sections.

7 "A sufficiently general point of view"

7.1 The puzzle of Sadi's audacity

Sadi's ambitions were very great. He did not seek specific remedies to improve the performance of this or that design of heat engine. Rather, he set a higher goal (pp. 43–44):

The phenomenon of the production of motion by heat has not been considered from a sufficiently general point of view. ... In order to consider in the most general way the principle of the production of motion by heat, it must be considered independently of any mechanism or any particular agent. It is necessary to establish principles applicable not only to steam engines*¹⁶ but to all imaginable heat-engines, what-ever method working substance by which it is operated.

Sadi succeeded. His theory is both very simple and, at the same time, of extraordinary scope. He could with the simple short argument sketched above settle what might otherwise appear to be intractable problems requiring solutions of great complexity. In an engine that operates by expanding fluids thermally, which of all fluids can get the most motive power from a given amount of heat? His answer: they all can, as long as the engine operates reversibly. What of an engine that utilizes some other working mechanism? Might there be one that works better? His answer: the choice of mechanism does not matter if we seek the greatest efficiency. All that matters is that the operation is reversible. How could the capacity to extract motive power from heat of some particular design of heat engine be improved? His answer: bring the component processes of the engine closer to reversibility; and operate between the highest and lowest temperatures available. These and many more similar questions were answered in a single stroke by Sadi's analysis.

It is important to realize just how audacious it was of Sadi to seek such a simple general theory, let alone to find it. The steam engines of Sadi's time were already devices of great complexity. They were then as now built of many disparate parts. There is a furnace burning a fuel; a boiler with water heated by the furnace to make steam; a piston in a cylinder that extracts motive power from the expanding steam; and mechanical couplings that conveyed that motive power to where it was to be

¹⁶ Sadi's footnote: "We distinguish here the steam-engine from the heat-engine in general. The latter may make use of any agent whatever, of the vapor of water or of any other, to develop the motive power of heat."

used, whether to pump water out of mines or to power a locomotive or a steamboat. One would surely expect that the efficiency of a compounded system could not be assessed by a single theory. Rather one would need to investigate the operation of each component individually and to find the best design for a particular circumstance through a delicate balancing of competing factors. Perhaps the conditions for optimal performance of high pressure steam systems might differ from those for a low pressure system, for example.

We can see that this was likely the prevailing attitude when Sadi wrote, if we consult a synoptic work on steam engines written almost exactly when Sadi wrote. Thomas Tredgold's (1827) *The Steam Engine* was published just 3 years after Sadi's *Réflexions* and was long recognized as the "best standard work on the subject."¹⁷ Its full title conveys its scope and ambitions: *The Steam Engine, Comprising an Account of its Invention and Progressive Improvements; with an Investigation of its Principles and the Proportions of its Parts for Efficiency and Strength: detailing also its application to Navigation, Mining, Impelling Machines, &c. and the results collected in Numerous Tables for Practical Use.*

Tredgold's account took the various components of a steam engine one at a time and mixed general consideration with quite specific matters of design. His 62 page Section II included a lengthy recounting of the physical properties various liquids and the vapors they produce. The account was rich in tabulations of experimental data, including the liquids' heats of vaporization and the "elastic forces" derivable from their vaporizations. The fluids included water, alcohol, sulphuric ether (now called diethyl ether), sulphuret of carbon (now carbon disulphide), turpentine, naphtha and more. The conclusion, offered only in the preface (p. vii) was "... that water is of all other known fluids that best adapted for introducing steam."

The same Sect. 2 included practical guidance for sizing passages for conveying steam. Readers were warned of a tradeoff. A larger aperture allowed for less loss of the elastic force of the steam (presumably, less pressure drop in modern terms); but this larger aperture produced a slower steam velocity that resulted in more cooling of the steam.

The account proceeded with this mix of general considerations and narrowly targeted specific guidance. Section 3 covered the design of boilers and furnaces. The remaining sections gave elaborate accounts of the various devices that could be employed to extract motive power from the steam generated by the furnace and boiler.

Sadi had considerable knowledge of the design and operation of the steam engines of his time. This is evident from the closing pages (pp. 112–26) of his work in which he makes quite specific recommendations for the improvement of the efficiency of existing steam engines on the basis of his general theory. What made him so bold as to imagine that a tractable, general theory of heat engines, covering all possible designs, lay within his reach? Why did he seek it as opposed to a narrower investigation into the optimization of the specific designs of steam engines then in operation?

¹⁷ An anonymous review in *The Mechanics Magazine*, Vol. XLIV, July 1st–December 30, 1848, on the occasion of the publication of a new, expanded edition of Tredgold's work, published after his death in 1829, began: "Tredgold on the steam engine has long been our best standard work on the subject..."

7.2 The puzzle solved

At least a major part of the solution lies, of course, in his father, Lazare's, *Essai*. For, as we saw in Sect. 2.1 above, there Lazare lamented the lack of a general account of ordinary machines. He set himself the task of finding such a theory and seemed satisfied with the results. Sadi could find in Lazare's work item (i) of the summary of Sect. 3, *A simple, universally applicable account of the efficiency of ordinary machines*.

Sadi's introduction in his *Réflexions* tells us directly of the work that provided the standard to which he aspired (p. 44):

Machines which do not receive their motion from heat, those which have for a motor the force of men or of animals, a waterfall, an air-current, etc., can be studied even to their smallest details by the mechanical theory. All cases are foreseen, all imaginable movements are referred to these general principles, firmly established, and applicable under all circumstances. This is the character of a complete theory.

Sadi has here just described his father's *Essai*, omitting only to name the author of the complete theory described. He continues to tell us that he plans to provide such a general theory for heat engines:

A similar theory is evidently needed for heat-engines. We shall have it only when the laws of Physics shall be extended enough, generalized enough, to make known beforehand all the effects of heat acting in a determined manner on any body.

We may well wonder if Sadi would have set himself so audacious a task as finding a general theory without the analogy to his father's work. Such questions are, of course, unanswerable. We cannot recreate a different past without Lazare's work to inspire Sadi. But we can say, even with the inspiration of Lazare's work, that it is extraordinary that Sadi should seek a general theory of heat engines. Lazare's ambitions seem less grand. For it seems not so far-fetched that there is a general account of levers, pulleys and waterwheels. They are each simple devices whose operation is readily understood in detail even by the simplest mechanic and which are plausibly governed by common principles. A complicated machine that combines many levers and pulleys is just a machine built of many parts all alike in fundamental constitutions. A principle that optimizes each component individually, will optimize the totality.

It must surely have seemed otherwise for heat engines. For, as was detailed above, they are complicated devices with many, disparate parts, each presumably governed by rather different principles. Yet Sadi persisted. Would he have had the courage to do so or even the interest in trying without the example of his father's work? What if his major source had been only practically-minded works such as Tredgold's *Steam Engine*?

8 More than an analogy?

That Lazare's work provided the standard Sadi set for himself is a conclusion that is hard to avoid. Just what role did that standard play? Was it merely a suggestive

analogy? Or were the analogical relations stronger? It is possible that we see a greater distance now between the machines of Lazare and the engines of Sadi than would have been apparent to Sadi? Might it even be for Sadi that the relationship to his father's theories was not merely one of analogy, but that Sadi's analysis was a direct application of Lazare's theories?

Sadi conceived the motion of caloric as the origin of a heat engine's motive power. We now know that heat is not a conserved fluid. Fluid talk for us is at best a useful heuristic fiction. It was not so for Sadi. Caloric was for him a real fluid. Moreover, he had Lazare's detailed analysis of other engines operated by moving fluids, most notably the waterwheels Sadi recounts. Fluids, such as water, were, for Lazare, really assemblages of very many corpuscles. He characterized them as (1808, p. 223):

We may regard a fluid as an assemblage of an infinity of solid corpuscles detached from each other; we may therefore apply to hydraulic machines all that we have said of other machines ...

Might Sadi have conceived his caloric fluid and the hydraulic fluids of Lazare as something much closer physically? That one fluid is wet and the other imponderable may just be an irrelevant difference when the analysis is elevated to the level of the most general theory. Both fluids are mobile, corpuscular media whose component corpuscles collide according to the rules of ordinary mechanics. They would then both conform with Lazare's characterization of fluids. The result would be that steam engines would be included within the scope of Lazare's theories and, more importantly, within the reach of Lazare's general principles. They would be treated at the general level exactly like hydraulic engines. From that perspective, Sadi might well have been able to conceive his theories not as inspired by an analogy to those of his father, but simply as a direct application of them.

This possibility must be left here as a mere possibility, for Sadi does not positively assert that this is his conception of the analysis of *Réflexions*. If that conception were foremost for Sadi, there would seem to be no reason to omit its mention.

Earlier speculations by Sadi suggest another way in which he might have seen heat engines as falling directly within the scope of Lazare's analysis. They are private notes written, apparently, prior to Sadi's *Réflexions*. The pertinent section of the notes begins with a collection of facts associated with the motion of bodies due temperature changes. The first fact is, apparently, a full endorsement of Lazare's dissipative ontology (Carnot, 1897b, p. 217):

1. *The Collision of Bodies*. We know that in the collision of bodies there is always expenditure of motive power. Perfectly elastic bodies only form an exception, and none such are found in nature.

Sadi proceeds to ponder the origin of the temperature increase that results from percussion, such as when metals are pounded. He concludes (p. 218):

It would seem, then, that heat set free should be attributed to the friction of the molecules of the metal, which change place relatively to each other, that is, the heat is set free just where the moving force is expended.

It appears that Sadi was willing to contemplate the conversion of work to heat, contrary to the notion of heat as conserved caloric. As his notes unfold, it becomes quite clear that just this is speculated. For example, he asks (p. 223).

Is heat the result of a vibratory motion of molecules? If this is so, quantity of heat is simply quantity of motive power.

Whatever may have been his misgivings about the conserved character of caloric, they did not survive in the main text of *Réflexions*. A trace of these misgivings, however, persists in his footnote defense mentioned above of the impossibility of perpetual motion. It includes the following query that reveals Sadi's deeper thoughts (p. 237):

... but is it possible to conceive the phenomena of heat and electricity as due to anything else than some kind of motion of the body, and as such should they not be subjected to the general laws of mechanics?

9 The impossible process

The second and, I believe, greater puzzle, is how Sadi came to the concept of a thermodynamically reversible process. It plays a central role in his analysis. To see why this is a greater puzzle, we need to pause and review the notion of a thermodynamically reversible process. The concept is not just strange. It is *very* strange; and its strangeness is not commonly recognized even today.

9.1 Thermodynamically reversible processes

The rough and ready formulation is that a thermodynamically reversible process is one that, at all its stages, is minutely removed from equilibrium. That means that all the forces that drive the process and resist it are almost exactly in perfect balance. If temperature differences move heat among bodies, those temperature differences are as slight as possible. If pressure differences drive a fluid motion or activate a piston, those pressure differences are similarly negligible. And so it is for all thermodynamic forces. This same precarious balance is assumed when an external magnetic field acts on the magnetic dipole moment of magnetized thermal medium.

This precarious balance is essential, for it is just what is needed if these processes are to be reversible. It takes only the slightest weakening of the driving force of a process for it to be overcome by the forces opposing the process and thus for the process to be reversed. Since the changes in forces needed for the reversal are so slight, the component system will pass through essentially the same states in the forward and the reversed process.

A widely recognized characteristic of these processes is that they proceed very slowly. For the net driving forces are just barely removed from equilibrium and thus just barely able to advance the process. Here we must guard against a common misreading. It is the near perfect balance of forces that characterizes a thermodynamically reversible process. The great slowness is a consequence of that near balance. Mere slowness is

not enough for a process to be thermodynamically reversible. A compressed gas in a balloon can be made to deflate with very great slowness merely by using a pinhole made as small as we like. This very slow deflation is an irreversible expansion of the gas. The driving forces are unbalanced. The internal pressure of the gas greatly exceeds the resisting pressure of the surrounding air. No slight adjust to them will reverse the process and lead the balloon to re-inflate.

While Sadi's analysis was limited to the efficiency of heat engines, this idea of thermodynamically reversible processes proved to have an application well beyond Sadi's steam engines. If we are to single out just one idea in Sadi's *Réflexions* that proved to be of central importance later, it is this one. The later development of thermodynamics came to be governed by Clausius' notion of thermodynamic entropy. The theory proved to be of extraordinary scope and generality. All real thermal processes—be they simple transfers of heat or the most complicated chemical reactions within a living cell—proceed only if they are entropically favored; that is, if they increase the total entropy of the systems in which they are found. The governing notion of thermodynamic entropy depends on Sadi's idea of a reversible process. It is essential to Clausius' (1865, p. 387) definition of entropy, which is still the one used today. That is, the incremental change dS in the entropy S of a system is given by $dS = dq/T$, where dq is the increment of heat gained by the system at temperature T in a *thermodynamically reversible* process. Sadi's most efficiently operating heat engines turn out to be those whose combined components operate at constant summed entropy.

9.2 They are very strange

This rough and ready characterization of thermodynamically reversible processes suffices for practical work in thermodynamics. However, inserted all the way through it, we find clumsy qualifications: “almost exactly in perfect balance,” “as slight as possible,” “precarious balance” and so on. One might imagine that they are easily discharged with just a little more attention to the details. They are not. They are masking what is the essential strangeness of thermodynamically reversible processes. They must by design meet two conditions that contradict¹⁸:

- the systems in the process are always in equilibrium states, so that they may pass through the same set of states in the forward and reversed direction.
- the systems must be away from equilibrium, for otherwise the systems stay as they are and the process does not advance in either forward or reversed directions.

More tersely, we can have a system in equilibrium that does not change; or we can have a system that does change because it is not in equilibrium. But we cannot have both change and equilibrium. Heat does not pass between bodies when they are at the same temperature and they are in equilibrium. Heat passes between bodies

¹⁸ These difficulties have been explored at greater length in Norton (2016). A survey of treatments of thermodynamically reversible processes extending back to the time of Carnot finds that almost none of them treat this inherent contradiction with adequate precision. This finding, was for me, surprising and disappointing.

when one is cooler than the other and they are not in equilibrium. Equilibrium and change contradict. Yet just this contradiction is constitutive of the very notion of a thermodynamic process.

It is a mistake to think that thermodynamically reversible processes are just another benign idealization of science.¹⁹ They are not. They are quite unlike the idealizations common in the science of Sadi's time and even in our time. A perfect sphere is never realized in our laboratories, but its existence entails no contradiction with geometry. A perfectly frictionless plane can never be built, but its absence is not derivable from the principles of mechanics. A thermodynamically reversible process, however, is internally contradictory. As a matter of logic, there can be no such thing.²⁰

9.3 Sadi's formulation of thermodynamically reversible processes

Given the delicacy and even oddity of the notion of the thermodynamically reversible process, we should review Sadi's account to find just what conception it contains. The review below will show that his account does contain the notion a reversible process just described in somewhat complete form at least for heat transfers. There is, however, no clear recognition that these processes were required to meet contradictory conditions.

Sadi's core formulation of the processes of greatest efficiency is: (pp. 56–57, his emphasis).

Now, very little reflection would show that all change of temperature which is not due to a change of volume of the bodies can be only a useless reestablishment of equilibrium in the caloric.*²¹ The necessary condition of the maximum is, then, *that in the bodies employed to realize the motive power of heat there should not occur any change of temperature which may not be due to a change of volume.* Reciprocally, every time that this condition is fulfilled the maximum will be attained.

Sadi immediately emphasized the centrality of this condition to his analysis:

This principle should never be lost sight of in the construction of heat-engines; it is its fundamental basis. If it cannot be strictly observed, it should at least be departed from as little as possible.

He then explored the failure of this condition (p. 57):

¹⁹ For a moderating view, see Valente (2019), and Palacios and Valente (2021, Sect. 4).

²⁰ How are we to conceive thermodynamically reversible processes? Norton (2016) proposes that a consistent account is possible if we replace the concept of a single process whose states are *per impossibile* always at equilibrium by a set of processes whose states are not at equilibrium but which approach arbitrarily closely to it. The properties attributed in standard accounts to the single, fictional reversible process are actually the unrealized limits of the properties of the sets of non-equilibrium processes.

²¹ Sadi's footnote: "We assume here no chemical action between the bodies employed to realize the motive power of heat. The chemical action which takes place in the furnace is, in some sort, a preliminary action—an operation destined not to produce immediately motive power, but to destroy the equilibrium of the caloric, to produce a difference of temperature which may finally give rise to motion."

Every change of temperature which is not due to a change of volume or to chemical action (an action that we provisionally suppose not to occur here) is necessarily due to the direct passage of the caloric from a more or less heated body to a colder body. This passage occurs mainly by the contact of bodies of different temperatures; hence such contact should be avoided as much as possible. It cannot probably be avoided entirely, but it should at least be so managed that the bodies brought in contact with each other differ as little as possible in temperature.

Here is a later version of the same result (p. 68, Sadi's emphasis):

... Thus we are led to establish this general proposition:
The motive power of heat is independent of the agents employed to realize it; its quantity is fixed solely by the temperatures of the bodies between which is effected, finally, the transfer of the caloric.

We must understand here that each of the methods of developing motive power attains the perfection of which it is susceptible. This condition is found to be fulfilled if, as we remarked above, there is produced in the body no other change of temperature than that due to change of volume, or, what is the same thing in other words, if there is no contact between bodies of sensibly different temperatures.

This condition of the minimal contact of bodies at different temperatures may seem excessively restrictive. For real steam engines operate with steam from boilers at much higher temperatures than the condensers to which the spent steam is eventually fed. Might Sadi have so restricted his account that it was remote from any real steam engine? Sadi readily answered the concern (p. 60):

The proposition found elsewhere demonstrated for the case in which the difference between the temperatures of the two bodies is indefinitely small, may be easily extended to the general case. In fact, if it operated to produce motive power by the passage of caloric from the body *A* to the body *Z*, the temperature of this latter body being very different from that of the former, we should imagine a series of bodies *B*, *C*, *D* ... of temperatures intermediate between those of the bodies *A*, *Z*, and selected so that the differences from *A* to *B*, from *B* to *C*, etc., may all be indefinitely small. The caloric coming from *A* would not arrive at *Z* till after it had passed through the bodies *B*, *C*, *D*, etc., and after having developed in each of these stages maximum motive power. The inverse operations would here be entirely possible, and the reasoning of page 52 would be strictly applicable.

In all these statements,²² Sadi's condition is not quite the modern condition. First, in the modern conception, a thermodynamically reversible transfer of heat is admissible just if the body supplying the heat is imperceptibly warmer than that receiving the heat. By maintaining that condition, one body can reversibly heat another. Sadi has the condition of avoiding contact of bodies with sensibly different temperatures. However,

²² Another version of the condition is provided in the concluding parts of his memoir. Sadi's (p.112) recommendation for the most efficient operation of a heat engine includes: ... the passage of the elastic fluid [gas or vapor in the heat engine] from the highest to the lowest temperature should be due to increase of volume; that is, it should be so arranged that the cooling of the gas should occur spontaneously as the effect of rarefaction.

it is always coupled with an extra condition that any resulting transfer of heat must be accompanied by a volume change somewhere or, more generally, the creation of motive power. While the modern conception allows this added condition, it does not require it.

Second, there is no explicit treatment of the balance of forces other than temperature differences. The modern conception requires, for example, that all pressure forces are in perfect balance or minutely removed from it. However, it takes only a slight charity to see that this further condition is implicit in Sadi's analysis, for without it the processes of his analysis would not have the requisite reversibility. This is clear in his treatment of adiabatic reversible processes, that is, those that involve no heat transfer. They appear explicitly later in the analysis when Sadi develops what we now know as the Carnot cycle (pp. 63–67). The cycle contains an adiabatic expansion of a gas and an adiabatic compression of the same gas. Sadi (p. 65–66) announces the complete reversibility of the processes.²³ The perfect reversal of these processes would only be possible if the pressures of the expanding or contracting gases were in the requisite equilibrium with the agencies receiving or supplying the motive power.

Finally, Sadi turned to the essential awkwardness of these processes. He conceded their impossibility, but dismissed the failure as one that could be arbitrarily minimized and thus ignored (p. 58):

In reality the operation cannot proceed exactly as we have assumed. To determine the passage of caloric from one body to another, it is necessary that there should be an excess of temperature in the first, but this excess may be supposed as slight as we please. We can regard it as insensible in theory, without thereby destroying the exactness of the arguments.

In a footnote, we find a clue as to how Sadi conceived the impossible demands of equilibrium and change (p. 53):

We may perhaps wonder here that the [cool] body B [used to condense steam] being at the same temperature as the steam is able to condense it. Doubtless this is not strictly possible, but the slightest difference of temperature will determine the condensation, which suffices to establish the justice of our reasoning. It is thus that, in the differential calculus, it is sufficient that we can conceive the neglected quantities indefinitely reducible in proportion to the quantities retained in the equations, to make certain of the exact result.

Here Sadi suggests that some limit process, such as is familiar in the calculus, can meet both demands. In the differential calculus, we compute the instantaneous speed of a body from the ratio of the distance covered in some small increment of time. We consider the limit of this ratio as the time increment becomes arbitrarily small. For common cases, this limit is well-defined. Sadi's case is unlike this case of the calculus. For as the temperature differences are made smaller, more time is needed to convey some fixed unit of heat. In the limit of zero temperature difference, we might be inclined to say that "infinite time" is needed to convey that unit of heat. This is just another way of saying that the conveyance never happens. If we have two bodies at

²³ "All the above-described operations may be executed in an inverse sense and order."

exactly the same temperature, no heat passes between them, after any finite time, that is, no matter how long we wait.

It is perhaps significant that nowhere in his work, as far as I have been able to discern, does Sadi acknowledge that his reversible processes would require infinite or even just an arbitrarily large time for their completion.

9.4 The puzzle (solved): how did Sadi come to posit such a strange notion?

This last section shows that Sadi proposed what is essentially the modern notion of a thermodynamically reversible process. It is, as emphasized above in Sect. 8.2, a most strange notion. It contradicts one of the most fundamental of distinctions in thermal systems: that between equilibrium and non-equilibrium systems. The proposal requires processes whose states are, at the same time, both. How could Sadi come up with such an extraordinary notion? That is, for me, the greatest puzzle in this history. Sadi's identification of this notion is of comparable importance, in my view, to Newton's recognizing that terrestrial gravity and celestial planetary forces are the same; and to Einstein recognizing that all will be well with electrodynamics and the relativity principle if he gives up absolute simultaneity.

The answer to the puzzle is, of course, the inspiration provided by the work of his father, Lazare. It led Sadi to his conception in two ways indicated in summary in Sect. 3 above.

First, we now recognize that thermodynamic processes are inherently dissipative. That is, using later concepts developed from Sadi's work, a thermodynamic process only advances if it increases thermodynamic entropy. We do not now think of processes in mechanics as providing a useful model for such inherently dissipative processes. For our most fundamental physical theories all operate with some version of the conservation of energy and momentum. The analogy is poor.

Lazare's work in the efficiency of machines provided a different conception. He proceeded from what is labeled as (ii) in Sect. 3: *A basic ontology for machines that is dissipative*. As a result, Lazare focused on what is needed to maximize efficiency in such fundamentally dissipative systems. At the broadest of levels, this was the problem facing Sadi in his project on heat engines. At this level, the problems are analogous.

Second, Lazare's work provided template solutions for the identification of which are the most efficient processes in such an ontology. That is point (iii) of Sect. 3: *A way to characterize the least dissipative processes in his ontology*. Lazare provided a repertoire of techniques for this. Repeatedly, Lazare insists on the elimination of all shocks or percussions. That is, all imbalances of ordinary forces are to be minimized or removed. All motions proceed by imperceptible degrees. That condition can be translated directly to the context of heat engines: all sensible differences of temperature are to be minimized or eliminated. This is, of course, the repeated characterization of Sadi's most efficient processes for heat engines.

Then, more importantly, Lazare's geometrical motions were characterized by their reversibility. That characterization reappears in Sadi's notion of the thermodynamically reversible process. Motive power transmitted by a geometrical motion can be recovered in its entirety by a reversal of the geometrical motion. Correspondingly, the

reverses of Sadi's reversible processes have the same restorative effect. They use a return of all the motive power to restore all caloric to its original sources; and all other components to their initial states. This restorative capacity of reversible processes then provides Sadi the means to prove his core reversibility result of Sect. 5 above.

9.5 Two anomalies in Sadi's account

That Sadi is working closely with the conceptions recovered from Lazare's work might help us explain two anomalous aspects of Sadi's conception of a reversible process described above. Unlike Sadi's account, the modern concept of a thermodynamically reversible heat transfer does not require that the transfer be accompanied by generation of motive power. Sadi's additional condition mimics Lazare's own prescription for the greatest efficiency of ordinary machines.

In his synoptic summary, Lazare considered a machine supplied with "momentum of activity" (loosely our modern work energy) Q that transmits a portion q of it usefully. To get the best out of a machine, two conditions must be met (1808, p. 298–299):

... 1st, the quantity Q must itself be the greatest possible; 2ndly, All this momentum Q must be solely employed in producing the effect proposed. ... This first condition being fulfilled, nothing remains to be done, to produce with any given machine the greatest effect possible, but to manage matters so as that the whole quantity Q is employed in producing this effect; for if this be done, we shall have $q = Q$; and this is all we can expect, since Q can never be less than q .

Lazare's standard of greatest efficiency is that "all this momentum Q must be solely employed in producing the effect proposed." If Sadi applies that standard to the processes in a heat engine individually, then any motion of heat must be accompanied by the generation of motive power. We now know that a thermodynamically reversible transfer of heat need not be associated directly with the generation of motive power. It can be a step in a larger process whose other steps produce motive without its presence reducing the overall efficiency of the process. Indeed, Carnot's own result on the maximum efficiency of reversible engines shows this.

Second, while Sadi recognizes the artificiality of his reversible processes, he does not recognize explicitly in his text the inherent contradiction supposed by them. Here again the model of Lazare's work might have misdirected him. In the ordinary machines Lazare considered, reversible geometrical motions do not contradict the basic laws of mechanics. We can have a system in which all forces balance perfectly, but a motion proceeds nonetheless. That motion is, in the simplest case, an inertially moving mass on which no net force acts. A more sophisticated example is Lazare's winch of Fig. 3. The condition for a geometrical motion is that the forces exerted by the two masses on each other balance perfectly. In that situation, the winch may not turn. Or, if its bearings are frictionless, the masses can move at uniform speed, as does the free inertial mass. The geometrical motion is realized, even though the forces are perfectly balanced.

This, then, is a significant disanalogy between Lazare's machines and Sadi's engines. Realization of the most efficient processes for Lazare's machines does not contradict the laws of mechanics. Realization of the most efficient processes of Sadi's

engines, however, does contradict basic thermal laws. Might it be that taking the model of Lazare's machines too seriously and trusting in the powers of infinitesimals in the calculus was sufficient to lead Sadi to overlook these contradictions?

10 The analogy

In sum, what was the analogy that guided Sadi's analysis in his *Réflexions*? Elsewhere (Norton, 2021, Ch. 4), I have provided a general account of analogical inference. These inferences are not based on some general notion of similarity. They are not distinguished by their conformity with a universal schema of analogical inference, as is the standard practice in philosophical treatments of analogical inference. Rather they are authorized by the truth of specific "facts of analogy" that express some relevant commonality for two systems and authorize inferences that span the two systems. Identifying these facts of analogy identifies the warrant for the analogical inferences and allows us to discern whether the inferences are well founded.

In the present case, the overarching fact of analogy is that Lazare's machines and Sadi's engines are both dissipative and in a sufficiently similar way that the conditions that lead to greatest efficiency in one will likely do the same in the other. At a general level, Lazare's machines are most efficient when all shocks and percussions are minimized. Sadi's engines are most efficient when all differences of temperature between contiguous bodies are minimized. This condition is realized in both systems by processes that are reversible.

Similarities such as these enable closely parallel inferences to be mounted for Lazare's machines and for Sadi's engines. The case of waterwheels and heat engines is easiest to see and most familiar. The lowering of water, a conserved fluid, from an elevated source to produce motive power by a waterwheel is similar to the transmission of caloric, another conserved fluid, from a high temperature source by a heat engine to produce motive power. The lowering of water and transmission of caloric do, of course, differ in many aspects. Water is wet, viscous and weighty; caloric is none of these. Where they agree, however, is in the properties needed to secure the core reversibility argument of Sadi's analysis, as given in Sect. 5 above and then replicated for water wheels in Sect. 6. Differences of height and differences of temperature are the origins of the motive power each yields; and, most important, it is possible near enough for the processes employed by each to be reversed.

It follows, using Carnot's celebrated argument, that a reversibly operated waterwheel and a reversibly operated heat engine are each the most efficient; and that the efficiency is determined just by the difference in water heights or differences in temperature. The arguments used to derive the results in the two contexts are so close that each can be converted one to the other merely by systematically switching terms: caloric for water and height for temperature.

The analogy between Lazare's and Sadi's analyses is robust and persists even if we alter details. For both are essentially dissipative in their operation and the general properties and modes of analysis for such systems are similar. For example, we might replace Sadi's analysis with the later Clausius-Thomson analysis, in which heat is a form of energy that is converted into work energy in a heat engine. The main elements

of the analogy to Lazare's analysis remains. We still find that the processes of greatest efficiency are those that minimize all imbalances of driving forces. They can be realized as reversible processes.

Similarly, we may replace Lazare's fundamentally dissipative processes of hard collisions by friction-limited motions. In the simplest case, imagine that we have a motion impeded by a frictional force F proportional and opposite in direction to the speed v of the motion. That is, $F = -kv$, for some constant $k > 0$. For the motion to pass distance L , it must dissipate energy $-FL = kvL$. Since k and L are fixed, this dissipation is minimized only by bringing v as close to zero as possible. It follows that the process requires an arbitrarily large time L/v for completion, while the frictional force $F = -kv$ becomes arbitrarily small. If this force is so reduced as to be minutely away from zero, we have realized in analogy a process reversible in the sense of thermodynamics. It takes arbitrarily long to be completed and can be reversed by the slightest alteration in the balance of forces acting.

11 Conclusion

Lazare Carnot's analysis of the efficiency of machines was based on an essentially dissipative ontology. At the most fundamental level, machines are systems of corpuscles interacting through hard, inelastic collisions. It was an ontology ill-fated within the developing mechanics of the century following. In the mid and later nineteenth century, Clausius, Maxwell and Boltzmann accounted for gases as collections of molecules undergoing non-dissipative, elastic collisions. They no longer had any use for the details of Lazare's analysis. Frictional dissipation could still arise in this non-dissipative ontology, but through a secondary process in which the energy of large body is distributed over the random motions of many smaller bodies as heat.

Prior to the development of thermodynamics, statistical mechanics and this account of frictional dissipation, Lazare's choice of a dissipative ontology may well have seemed to him the only viable choice. For if the fundamental ontology is conservative, would not all machines be equally efficient? Whatever may have directed Lazare's choice of this ill-fated dissipative ontology, it was most fortuitous for Sadi. For Lazare mapped out ways of understanding systems that are inherently dissipative. When Sadi turned to analyze just such a system, heat engines, he had available to him the model of Lazare's work. He could copy its ways and methods and, using them, devise the basis of what becomes the modern theory of thermodynamics.

Appendix 1: Lazare's demonstration of his "first fundamental equation"

The dynamics of the system of Lazare's Section XV of his (1808, 1809) resides in the interactions of each corpuscle with those of its neighbors with which it interacts. The first step in the analysis considers just the pairwise interaction of two of these neighbors. That interaction is taken to be a hard body collision. Lazare does not have a notation adequate to keep track of just which mass is interacting with each other mass.

Without it, the analysis becomes opaque. Here I augment his notation by designating each mass m_i with an index $i = 1, 2, 3, \dots$. This same index is used to identify the speeds associated with each mass.

Assume mass m_i collides with mass m_k . Their speeds prior to the collision are W_i and W_k ; their speeds after the collision are V_i and V_k ; and the (negative) change in speeds are U_i and U_k . The force exerted on mass m_i by mass m_k is denoted by F_{ik} ; and the reaction force exerted on m_k by mass m_i is denoted by F_{ki} . The angle between the after-collision speed V_i of mass m_i and the force F_{ik} is q_{ik} ; and the angle between the after-collision speed V_k mass m_k and the force F_{ki} is q_{ki} .

The collision is resolved by the application of the two laws given in the main text. Immediately after the collision, the speeds of the two bodies in the direction of the interaction are $V_i \cos q_{ik}$ and $V_k \cos q_{ki}$. Lazare’s second law requires that these speeds be equal. The equality is expressed as $V_i \cos q_{ik} = - V_k \cos q_{ki}$, where the minus sign allows for the fact that the two speeds are evaluated in opposite directions. That is, we have

$$V_i \cos q_{ik} + V_k \cos q_{ki} = 0 \tag{Lazare/s equation label} \quad (\text{A})$$

From Lazare’s first law we have that action equals reaction,²⁴ that is $F_{ik} = F_{ki}$. Multiplying successive terms in (A) by each we have

$$F_{ik} V_i \cos q_{ik} + F_{ki} V_k \cos q_{ki} = 0 \tag{Lazare/s equation label} \quad (\text{B})$$

Lazare now sums his equation over all pairs of interacting masses to arrive at

$$\sum_{i,k} F_{ik} V_i \cos q_{ik} + \sum_{i,k} F_{ki} V_k \cos q_{ki} = 0 \tag{App 1}$$

where the summation over i, k is taken only over pairs of interacting masses. Lazare writes this equation somewhat inadequately as

$$s F' V' \cos q' + s F'' V'' \cos q'' = 0$$

where the symbol s indicates “sum.”

The equation in this form is not yet suitable for the next stage of the analysis. First, we need to note that there is a duplication of terms in Eq. (App 1) that follows from the pairing of action and reaction. That is, for each term summed in $\sum_{i,k} F_{ik} V_i \cos q_{ik}$, there will be an identical term in the second sum $\sum_{i,k} F_{ki} V_k \cos q_{ki}$; and conversely. For example, the term $F_{12} V_1 \cos q_{12}$ arises in the first sum when $i = 1$ and $k = 2$. However this same term arises in the second sum when $k = 1$ and $i = 2$. Hence

²⁴ Here Lazare’s sign conventions are inconsistent. If the velocity components of Eq. (A) have opposite signs because they have opposite directions, then the same should be true of the forces of action and reaction. Instead of $F_{ik} = F_{ki}$, we should have $F_{ik} = - F_{ki}$. Using a consistent sign convention, we would have $V_i \cos q_{ik} - V_k \cos q_{ki} = 0$ for (A). When it is multiplied by $F_{ik} = - F_{ki}$, we would recover (B).

Eq. (App 1) is just twice the simpler and more usable expression

$$\sum_{i,k} F_{ik} V_i \cos q_{ik} = 0 \tag{App 2}$$

where once again the summation over i, k is taken only over pairs of interacting masses.

Next, we need to eliminate the explicit presence of the summation over k . For some fixed value of i , the summation just over k of

$$\sum_k F_{ik} \cos q_{ik}$$

is the component in the direction of V_i of the net force exerted on mass m_i by all the other masses with which it interacts. That is, we write this net force as F_i . It is the resultant of the combination of all the individual forces F_{ik} due to all masses m_k that exert a force on mass m_i . If this resultant force acts at an angle q_i to the after-collision velocity V_i we have for its component in the direction V_i

$$F_i \cos q_i = \sum_k F_{ik} \cos q_{ik}$$

Using it, Eq. (App 2) adopts the simpler form

$$\sum_i F_i V_i \cos q_i = 0 \tag{App 3}$$

where the summation over i is now taken over all masses.

This transformation, from Eqs. (App 1) to (App 3), is absent from Lazare’s narrative. Without it, the ensuing stage of the calculation is unintelligible. It is possible that Lazare intended the transition to be conveyed by text for which I can discern no other purpose (p. 212):

We shall therefore have for the whole system $s F V \cos q = 0$ or $s V F \cos q = 0$ (C)...

If so, then equation (App 3) would correspond with Lazare’s equation “(C).” However, if that is the intent behind the text, it is a striking expository failure.

The second stage of the calculation begins by considering what portion of the after-collision speed V_i is due to the collision. If the angle between the before-collision speed W_i and the after-collision speed V_i is X_i , then the component of W_i already in the direction of V_i is $W_i \cos X_i$. Hence the portion of the speed V_i due to the collision is $(V_i - W_i \cos X_i)$.

Recall that Lazare’s version of Newton’s second law was an impulsive version: the force is set equal to the *change* of motion resulting from an impulse, not the later *rate of change* of motion. Hence the component of the net force F_i acting on mass m_i in the direction of V_i is $m_i (V_i - W_i \cos X_i)$. In the context of developing Eq. (App 3),

we arrived at an equivalent expression for this force component, $F_i \cos q_i$. Setting the two expressions equal, we have:

$$m_i(V_i - W_i \cos X_i) = F_i \cos q_i$$

Multiplying both sides by V_i and summing over all masses, we recover

$$\sum_i m_i V_i (V_i - W_i \cos X_i) = \sum_i F_i V_i \cos q_i = 0 \tag{App 4}$$

where the zero value follows from Eq. (App 3). Define U_i as that speed that when combined with V_i results in W_i . (That is, in modern vector representation, we have $\mathbf{W}_i = \mathbf{V}_i + \mathbf{U}_i$.) If Z_i is the angle between V_i and U_i , this summation is expressed in terms of component speeds in the direction of V_i as

$$W_i \cos X_i = V_i + U_i \cos Z_i$$

Substituting this expression for $W_i \cos X_i$ into Eq. (App 4), we recover

$$\sum_i m_i V_i U_i \cos Z_i = 0 \tag{Lazare/s equation label} \tag{E}$$

It is Lazare’s “first fundamental equation.”

Appendix 2: Lazare’s demonstration of the conservation of vis viva

Lazare represented motions by tracking their speeds and, separately, their directions. The later vector analysis combined the two into a single vector quantity. If we index the corpuscles by $i = 1, 2, 3, \dots$, we can represent their masses as m_i , their velocities prior to collision \mathbf{W}_i , their velocities after collision \mathbf{V}_i and the loss of velocity in collision for each mass, $\mathbf{U}_i = \mathbf{W}_i - \mathbf{V}_i$. The “first fundamental equation” (E), written in vector form is just²⁵

$$\sum_i m_i \mathbf{V}_i \cdot \mathbf{U}_i = 0 \tag{Ea}$$

We form the scalar quantity

$$\sum_i m W_i^2 = \sum_i m (\mathbf{V}_i + \mathbf{U}_i) \cdot (\mathbf{V}_i + \mathbf{U}_i) = \sum_i m_i V_i^2 + \sum_i m_i U_i^2 + 2 \sum_i m_i \mathbf{V}_i \cdot \mathbf{U}_i$$

²⁵ Unit vectors in the directions of \mathbf{V}_i and \mathbf{U}_i are \mathbf{V}/V_i and \mathbf{U}_i/U_i . The cosine of the angle between \mathbf{V}_i and \mathbf{U}_i is the inner product of the two unit vectors. That is, $\cosine Z_i = (\mathbf{V}_i \mathbf{U}_i) / (V_i U_i)$. Substituting this expression for the cosine into (E) returns (Ea).

where W_i , V_i and U_i are the norms $|\mathbf{W}_i|$, $|\mathbf{V}_i|$ and $|\mathbf{U}_i|$. Applying (Ea), this equation reduces to

$$\sum_i m_i W_i^2 = \sum_i m_i V_i^2 + \sum_i m_i U_i^2 \quad (1A)$$

The inference to the conservation of vis viva now proceeds as in the main text.

References

- Balmer, R. T. (2011). *Modern engineering thermodynamics*. Elsevier/Academic Press.
- Carnot, H. (1897a). Life of Sadi Carnot. In H. Carnot (Ed.), *Reflections on the motive power of heat* (pp. 20–36). Wiley.
- Carnot, L. (1783). *Essai sur les machines en general*. Defay
- Carnot, L. (1803). *Principes fondamentaux de l'équilibre et du mouvement*. Paris
- Carnot, L. (1808). Essay upon machines in general. *Philosophical Magazine*, 30, 8–15, 54–158, 207–221, 310–320; 31, 28–36, 136–144, 220–228, 295–305.
- Carnot, L. (1809). Essay upon Machines in General. *Philosophical Magazine*, 32, 124–130.
- Carnot, S. (1824). *Réflexions sur la Puissance Motrice du Feu*. Paris: Bachelier. Trans., *Reflections on the Motive Power of Heat*. Wiley. 1897.
- Carnot, S. (1897b). Appendix A: Extracts from unpublished writings of Carnot. In S. Carnot (Ed.), *Reflections on the motive power of heat* (pp. 205–236). Wiley.
- Clausius, R. (1865). Ueber verschiedene für die Anwendung bequeme Formen der Hauptgleichungen des mechanischen Wärmetheorie. *Annalen der Physik Und Chemie*, 125, 353–400.
- Coulomb, C. A. (1782). *Théorie des machines simples en ayant égard au frottement de leurs parties et a la roideur des cordages: piece qui a remporté le prix double de l'Académie des sciences pour l'année 1781*. Moutard.
- Diderot, D., & d'Alembert, J. L. R. (1776). *Encyclopédie, ou Dictionnaire raisonné des sciences, des arts et des métiers* (Vol. 9). Samuel Flache & Cie.
- Gillispie, C. C., & Pisano, R. (2014). *Lazare and Sadi Carnot: A scientific and filial relationship* (2nd ed.). Springer.
- Koetsier, T. (2007). Lazare Carnot's theory of machines and the background of Ampère's introduction of the word kinematics. In: *13th National Conference on Mechanisms and Machines (NaCoMM07)*, (pp. 29–35).
- Lemons, D. S. (2019). *Thermodynamic weirdness: From Fahrenheit to Clausius*. MIT Press.
- Maxwell, J. C. (1871). *Theory of heat*. Longman, Green, and Co.
- Müller, I. (2007). *A history of thermodynamics: The doctrine of energy and entropy*. Springer.
- Norton, J. D. (2004). Einstein's investigations of Galilean covariant electrodynamics prior to 1905. *Archive for History of Exact Sciences*, 59, 45–105.
- Norton, J. D. (2006). Atoms entropy quanta: Einstein's miraculous argument of 1905. *Studies in History and Philosophy of Modern Physics*, 37, 71–100.
- Norton, J. D. (2016). The impossible process: Thermodynamic reversibility. *Studies in History and Philosophy of Modern Physics*, 55, 43–61.
- Norton, J. D. (2021). *The material theory of induction*. BSPS Open. University of Calgary Press.
- Palacios, P., & Valente, G. (2021). The paradox of infinite limits: A realist response. In T. D. Lyons & P. Vickers (Eds.), *Contemporary scientific realism the challenge from the history of science*. Oxford University Press.
- Thomson, W. (1852). On the dynamical theory of heat, with numerical results deduced From Mr. Joule's equivalent of a thermal unit, and M. Regnault's observations on steam. *Philosophical Magazine*, 4(Ser. 4), 8–21, 105–117, 168–176, 256–260.

Tredgold, T. (1827). *The steam engine*. J. Taylor.

Valente, G. (2019). On the paradox of reversible processes in thermodynamics. *Synthese*, 196, 1761–1781.

Publisher's Note Springer Nature remains neutral with regard to jurisdictional claims in published maps and institutional affiliations.