

Infinite Pains: The Trouble with Supertasks

John Earman and John D. Norton

1 Introduction

A supertask is a task which requires that an infinite number of acts or operations be performed in a finite span of time. Supertasks have tormented us ever since Zeno noticed that a runner must traverse an infinite number of ever smaller intervals if he is to complete the race. The torment has proven immensely profitable, since it has forced us to clarify our notions of infinity, continuity and continuum, a process that has been significantly furthered even within the last century. However, in spite of millennia of work, the literature on supertasks, to which Paul Benacerraf (1962) made a seminal contribution, remains in an unfinished and unsatisfactory state.

Our purpose in this paper is pessimistic and optimistic. On the one hand we wish to indicate a direction of research on supertasks which we believe is no longer philosophically informative. On the other we will indicate a new direction which promises to be revealing in so far as it succeeds in drawing together notions of infinity and logic with some of the most vexing, outstanding problems in spacetime physics. And we shall indicate how Paul Benacerraf's work has pointed towards both our conclusions.

Our pessimistic conclusion is that our notions of infinity and continuity are now so well developed that supertasks have lost their power to force refinement of these notions. That is not to say that supertasks are now unworthy of study, for puzzling contradictions are still delivered by them. Our point is that the contradictions they deliver no longer reveal deficiencies in our concepts. We shall urge that the contradictions arising in known supertasks derive from fallacious reasoning or indefensible assumptions and these contradictions can be removed without requiring us to assume some conceptual incoherence in the very notion of supertask. In sections 2 to 7, in order to make good this claim, we will

review and defuse a selection of supertask paradoxes which, by general consensus, represent the most serious challenges to the coherence of supertasks. In section 8 we will then try to identify some patterns of fallacious reasoning that have contributed to the notion that supertasks are incoherent.

Our optimism pertains to a new species of supertask that can be used to address within the philosophy of mathematics finitist scruples indicated by Weyl in section 9. Traditionally we conceive of the finite time duration of the supertask as experienced by the person or machine attempting to carry out the infinite number of acts. These we call "proper supertasks." If an *infinity* of time is allowed to the agent that carries out the infinity of tasks but a separate observer witnesses the completion of the infinity of acts in a finite time, then we have a "bifurcated supertask." We will show in section 10 how bifurcated supertasks may be carried out in certain relativistic spacetimes. In such spacetimes, we may build an infinity machine which would allow an observer to witness the completion of an infinite computation. In section 11 we will indicate how these may be used to construct computing machines that transcend the normal boundaries of finite computation and, in section 12, we will explore the computational limits of these machines. In section 13 we will consider the implications of these machines for the philosophy of mathematics. Finally, section 14 offers some concluding remarks.

2 Zeno's Dichotomy

The archetype of the supertask is Zeno's celebrated "Dichotomy." According to it, a runner can never complete the race since he must first run to the half way point, and then to the half way point of the remainder and so on indefinitely.¹ The standard resolution simply accepts as unobjectionable Zeno's notion that to complete a journey from A to B , a runner must complete an infinite number of subjourneys – from A to the midpoint of AB , then from there to the three-quarter point, etc. but claims that this of itself does not prevent completion of the journey.

Max Black (1950–51) was unconvinced. Like most modern skeptics of the standard resolution, he accepted that the total distance traversed $1/2 + 1/4 + 1/8 + \dots$ approaches the finite value of unity in some suitable sense of the limit. The difficulty he identified lay deeper. He reasoned that it is logically impossible to complete an infinite number of journeys in a finite time, no matter how much faster or easier each successive journey becomes. John Wisdom (1951–52) agreed in the main with Black but added his own alternative resolution which appealed to the

idea that points of physical space have a finite extension. Whitrow (1980, section 4.4) sought a similar escape in the assumption that time is not continuous.

Black's fallacy lies in confusion of two senses of "incompletable" and its allure lies in the ease with which we can slide between the two senses.² An infinite sequence of acts is incompletable in the sense that we can nominate no last act, the act that completes it. An infinite sequence of acts may also be incompletable in the sense that we cannot carry out the totality of all its acts, even though each act individually may be executable. This may become the case, for example, in the runner's journey, if the runner is required to spend equal time in each of the infinitely many intervals. An infinite sequence of acts cannot be completed in the first sense, but that certainly does not entail that it cannot be completed in the second sense.

The deeper problem with Black and Wisdom's conclusion is that it preempts the use of continua in physical theories involving motion. If Wisdom's escape were correct, we would have a philosophical demonstration of the falsity of the major theories of modern physics, all of which take for granted that spacetime is a continuum. Of course, it is conceivable that attempts to marry quantum physics and the general theory of relativity will force the abandonment of the continuum concept for space and time. But the notion that armchair philosophizing – and not very good armchair philosophizing at that – can achieve the same aim gives philosophy a bad name.

While this unhappy outcome would seem to protect Zeno's runner from charges of logical inconsistency, that protection need not extend to all supertasks. Such was James Thomson's (1954–55) claim. He agreed with Black that it is logically impossible to complete an infinity of acts – as long as they are honest-to-goodness acts and not the debased imitations that Zeno has tried to slip by us in the Dichotomy. Here is Benacerraf's admirable summary of Thomson's position.

If we have made a continuous uninterrupted journey from A to $B \dots$ [then] our motion can be analyzed as covering in turn AA' [$1/2$ of AB], $A'A''$ [$1/4$ of AB], etc. [But] to say of someone that he has completed an infinite number of journeys (in *this* sense) is just to describe in a different (and possibly somewhat peculiar) way the act he performed in completing the single continuous journey from A to B . No absurdity is involved with the feat. If, however, we think of "completing an infinite number of journeys" as completing an infinite number of physically distinct acts, each with a beginning and an end, and with, say, a pause of finite duration between any two, then according to Thomson \dots it is logically absurd that one should have completed an infinite number of journeys. (Benacerraf, 1962, p. 105)

Thomson's idea is that a genuine supertask involves an infinity of "physically distinct acts" and that genuine proper supertasks are logically impossible.

This attempt to separate the genuine and impossible supertasks from the fake and achievable fails in so far as it turns out to be possible to represent the journey of Zeno's runner as an infinite sequence of distinct acts. Therefore any inherent impossibility of a supertask would still be inherited by motion in continua. To see this, suppose that finite pauses between subtasks are required of "physically distinct acts," e.g. the runner is required to run in a staccato fashion, pausing at the one-half mark, the three-quarter mark, etc. Mathematically there is no problem in constructing such an example, the most obvious prescription being that the runner traverses $1/2$ of AB in $1/4$ second and then rests for $1/4$ second, traverses the next $1/4$ of AB in $1/8$ second and then rests for $1/8$ second, etc. However, as Grünbaum (1969, p. 212; 1970, p. 212) notes, since this prescription has the runner complete each of the staccato runs at the same average speed, at the terminal instant his velocity will have a finite discontinuity while his acceleration will have an infinite discontinuity. Since there are no hard and fast criteria for what counts as kinematically and dynamically possible in the Newtonian setting, it is unclear whether such discontinuities disqualify the staccato runner from such a status. Fortunately there is no need to dwell on this matter since Richard Friedberg (as reported by Grünbaum 1969, pp. 213–14; 1970, pp. 215–16) has shown how the constant average velocity of the above simple minded staccato runner can be replaced with diminishing average velocities in such a way that his velocity and acceleration functions display no discontinuities. If $a(t)$ is the acceleration function of this sophisticated staccato runner and m is his mass, then the force function is defined to be $F(t) = ma(t)$. We can imagine that in some possible Newtonian world $F(t)$ is the force that the runner experiences, say, as a result of being in an anti-Elementian field. Newton's laws of motion then guarantee that the runner performs a supertask.

What this example and the one in the following section furnish are relative consistency proofs – proofs of the consistency of the proposition that a genuine proper supertask is completed, relative to the assumption that Newtonian mechanics harbors no internal contradictions. We can offer no proof of the latter assumption and, hence, no absolute proof of the consistency of genuine proper supertasks. At the same time, we see no reason to think that the completeness of supertasks within the Newtonian framework gives any reason to suspect that the framework is not consistent.

Of course, by loading demands onto the runner, we can assure that his staccato run is incompatible with plausible constraints for kinematical or

dynamical possibility within the Newtonian framework. For example, Grünbaum (1969, 1970) notes that requiring the runner not only to pause between successive subruns but also to plant a flag, which must be rotated each time through a minimal angle, leads at the terminal instant to an infinite discontinuity in the velocity of his hands.³ But the fact that some supertasks are kinematically or dynamically impossible is no more surprising or disturbing than the fact that some ordinary tasks are kinematically or dynamically impossible.

3 The Bouncing Ball

Can an infinity of physically distinct actions be completed in a finite time? The analysis of the staccato run seems to suggest it can. However our imagination may balk at the problem of conceiving circumstances in which the anti-Elementic force function $F(t)$ may arise. That problem disappears if we consider the bouncing ball, which seems to give as compact an illustration as we can expect of the logical consistency of completing an infinity of acts in a finite time, even when there are discontinuities in the physical quantities.

A ball bounces on a hard surface. The successive bounces are, we submit, "physically distinct" even though there is no pause between them. With each bounce its speed on rebound is reduced to a fraction k of its speed immediately prior to the bounce, where $0 < k < 1$ (see Figure 11.1). We assume a somewhat idealized ball which is perfectly elastic and

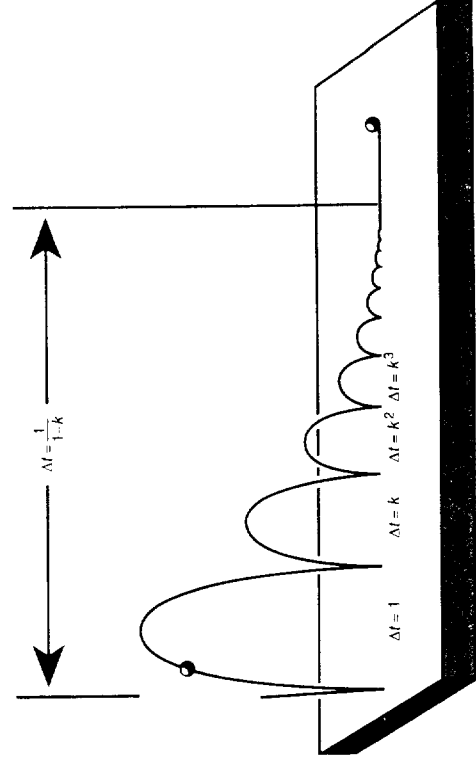

Figure 11.1 The bouncing ball

for which each bounce takes no time. Under these assumptions, the ball cannot come to (vertical) rest after finitely many bounces. For no bounce can be the last; each is followed by another with a fraction k of its initial speed. In classical mechanics, the time between bounces is directly proportional to the initial speed of the ball. Therefore if we assume that the time between the first and second bounce is unit time, the times between the successive bounces will form a geometric series, $1, k, k^2, k^3, \dots$. The sum of the series is $1/(1 - k)$, which is finite. So the ball completes an infinite number of bounces in coming to rest in a finite time, thereby completing a supertask.

The bouncing ball is not paradoxical in any obvious way, unless one is simply offended by the notion that it will complete infinitely many bounces in a finite time. Of course, only an idealized ball can behave in this way. All real balls are deformed somewhat on bouncing and will cease to bounce off the table's surface after some finite number of bounces. However, the issue is not whether the idealized ball could be realized in our world. It is whether there is some consistent setting in which it can execute its behavior. Our claim is that there is a consistent setting and, moreover, one that is not all that far away in possibility space from the actual world.

4 The Thomson Lamp

There seems little prospect Zeno's Dichotomy hides genuine paradox or that the very notion of completing an infinite sequence of acts is logically contradictory. Yet, in his quest to prove the latter, Thomson (1954-55) generated a supertask that purports to be logically contradictory.¹

Starting at 11:59 PM a lamp is switched ON and OFF more and more rapidly according to the following schedule:

<i>Stage</i>	<i>Operation</i>	<i>Time of completion</i>
1	Switch the lamp to the ON position	11:59.5 PM
2	Switch the lamp to the OFF position	11:59.75 PM
3	Switch the lamp to the ON position	11:59.875 PM
etc.	etc.	etc.

At 12:00 PM the lamp must be either be in the ON state or the OFF state. Thomson argued that neither state is possible. The lamp cannot be ON

(he reasoned) because for every time $t < 12:00$ PM such that the lamp is ON there is a t' such that $t < t' < 12:00$ PM such that the lamp is OFF. For the exactly similar reason the lamp can't be OFF at 12:00 PM. Contradiction.

The argument is seductive, but fallacious and Benacerraf (1962) showed how. From Thomson's schedule of switching

it follows only that there is no time between [11.59 PM] and [12:00 PM] at which the lamp was on and which was not followed by a time also before [12:00 PM] at which it was off. Nothing whatever has been said about the lamp at [12:00 PM] or later. (p. 107)

Indeed if the supertask is to force a contradiction then we must

suppose that a description of the physical state of the lamp at [12:00 PM] (with respect to the property of being on or off) is a logical consequence of a description of its state (with respect to the same property) at times prior to [12:00 PM]. (p. 108)

To put it another way, the lamp is not paradoxical since any lamp setting at 12:00 PM is compatible with the schedule of switching prior to 12:00 PM.

The point is made by observing that we can conceive of plausible consistent mechanisms which execute the above supertask and leave the lamp in any nominated setting at 12:00 PM. Grünbaum (1970, pp. 233-7) gave an example of how such a mechanism can be constructed, where the details of the switching mechanism are filled in so that the outcome is that the lamp is ON at 12:00 PM. The idea is to have the distance the moving part of the switch has to travel to make electrical contact diminish with each successive punch in such a way that at 12:00 PM the switch is in, and remains in, the contact position. The mechanism can be generalized by using the bouncing ball to effect the switching in a way compatible with Newtonian dynamics. Moreover slight alterations in the mechanism allow it to leave the lamp either ON or OFF at 12:00 PM. See Figure 11.2 in which the ball executes and infinite series of bounces that are completed at 12:00 PM exactly. The ball has a conductive coating and makes electrical contact with the plate upon each bounce. In the first circuit depicted, contact with the plate conducts electricity to the lamp, switching it ON, so that the final state of the lamp at 12:00 PM is ON. In the second circuit depicted, contact with the plate diverts current from the lamp switching it OFF, so that the final state at 12:00 PM is OFF.

If Benacerraf is right that the history of switching prior to 12:00 PM fails to specify the lamp state at 12:00 PM, then what remains to be

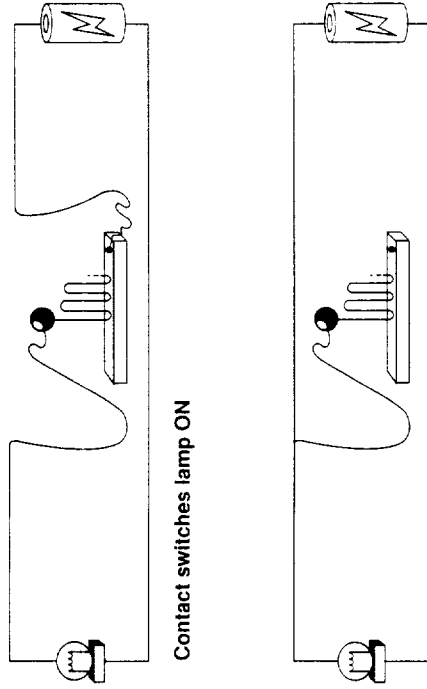

Figure 11.2 Alternative switching mechanisms for Thomson's lamp

explained is why so many naturally conclude otherwise and as a result believe that a contradiction is straining to emerge. This conclusion, we urge, depends upon tacitly introducing an assumption about the familiar behavior of lamps. That assumption is benign in normal circumstances but invites disaster when supertask switching is invoked. Informally we assume that if a lamp is left unswitched, it persists in its current state. Therefore the state of the lamp at a time when it is not switched is automatically fixed by the prior history of switching.

To see why this persistence property fails, represent the lamp state numerically at time t as $\text{lamp}(t) = 0$ or 1 according to whether the lamp is OFF or ON. This persistence property amounts

$$\text{to requiring that } \text{lamp}(t) = \lim_{t' \rightarrow t} \text{lamp}(t') \text{ at the time } t \text{ at}$$

which there is no switching. If this persistence property is to determine the state of the lamp at $t = 12:00$ PM from the history of prior switching, then clearly we arrive at a contradiction. That history of switching has been contrived precisely to ensure that the limit invoked in the property fails to exist. Our conclusion is not that the completion of the infinite schedule of switching is contradictory. Rather it is contradictory when coupled with the assumption of the persistence property. Notice that the infinite switching machines such as in Figure 11.2 are able to yield a definite lamp state at 12:00 PM exactly because a property other than

persistence fixes their state at 12:00 PM. Any attempt to construct a mechanism for Thomson's lamp that uses the persistence property to set the lamp at 12:00 PM must fail. The machine must be constructed to satisfy an inconsistent specification. This is clearly impossible in any consistent physical setting.⁵

5 Ross' Paradox

While the Thomson lamp depends on the non-existence of a limit, another supertask purports to be paradoxical⁶ precisely because a limit exists – but it is not the one we expect! Imagine an urn of infinite capacity and an infinite pile of balls labeled 1, 2, 3, Starting at 11:59 PM the balls are put into and taken out of the urn according to the following schedule:

Stages	Operation	Completion time
1	Put in balls 1–10; remove ball 1	11:59.5 PM
2	Put in balls 11–20; remove ball 2	11:59.75 PM
3	Put in balls 21–30; remove ball 3	11:59.875 PM
etc.	etc.	etc.

At 12:00 PM the system will have passed through an infinity of stages. In each of the stages a net of 9 balls has been added to the urn. So we can reason that at 12:00 PM the urn will contain $9 \times \infty = \infty$ balls. However, we can also reason that at 12:00 PM the urn will be empty, since for every ball there is a stage at which it was removed. (All the balls are numbered, and ball n was removed at stage n .)

As matters stand, it is meaningless to speak of the resolution of Ross' paradox since the problem is underdescribed. (This is a not uncommon feature of the discussion of supertasks.) The difficulty is that there are two natural conditions each of which fix the number of balls in the vase at 12:00 PM, but at different values. And the account of the paradox does not clearly allow a choice between them. First is the assumption that the history of each ball can be represented in a spacetime by a world line (or world tube). These world lines are assumed to be continuous and once the world line (or world tube) of a ball exits the spacetime region corresponding to the urn, it never reenters. It follows that at 12:00 PM the urn is empty. Second, we can consider the number function $N(t)$ which

counts the number of balls in the urn at time t and require this function to be continuous at any time t at which no ball is added or removed from the vase. That is, at such a t , $N(t) = \lim_{t' \rightarrow t} N(t')$. Since $t = 12:00$ PM is such an instant and the appropriate limit diverges, it would follow that the urn contains infinitely many balls at 12:00 PM.

We follow Allis and Koetsier (1991) in choosing the condition of world line continuity which entails that the urn is empty at 12:00 PM. This choice is favored by the numbering of the balls, which suggests that they retain their individual identity through time. It also follows from choosing the simplest spacetime picture for the kinematics of the balls.⁷ The condition of world line continuity can be maintained consistently provided we allow the failure of the requirement of continuity of the number function $N(t)$ at 12:00 PM. That is, the number function increases without limit with each stage as 12:00 PM is approached, whereupon it falls discontinuously to zero.

Suppose that the above schedule is changed so that at each stage 10 balls are added while at stage n ball number $10n$ is removed. Then on the analysis we favor, the urn will contain an infinite number of balls at 12:00 PM. So some schedules of adding a net of 9 balls at each stage lead ultimately to an empty urn while others lead to a stuffed urn. This makes it interesting to ask what will happen if at each stage the ball to be removed is chosen randomly. Ross (1988, pp. 68–70) shows that with probability 1 the urn will be empty at 12:00 PM.

Van Bendegem (1994) has been unable to resist the charms of each of the conditions of world line and number function continuity. He accepts both and concludes that Ross' paradox represents an impossible supertask. He attempts to explain the contradiction by showing that the operations involved are incompatible with the following assumptions: (K1) Infinite speeds are not allowed, (K2) Infinite accelerations are not allowed, and (K3) There is a largest speed L . However, the invocation of the relativistic constraint (K3) seems to us inappropriate since what is being claimed is not that Ross's paradox represents a physically impossible supertask in the actual world but a conceptually impossible supertask.

What remains is to make more plausible the possibility of failure of continuity of the number function $N(t)$. What is puzzling is that the number count, which one moment is growing without bound, suddenly evaporates the next. In brief this evaporation is simply an artefact of our subtraction of one infinite set from another. It is surprising but not contradictory. Such evaporation cannot happen with the subtraction of finite sets, where our intuitions are developed. Perhaps we can make this evaporation more comfortable by considering

a structurally similar case in which it occurs – but in which the evaporation is anxiously anticipated.

6 The Pyramid Marketing Scam

This common scam involves the sale of dealerships in a product whose nature is incidental to the scheme. To initiate the scam, an agent sells a dealership to two new agents for some unit amount – say \$1,000. At the end of this first stage, the first agent has made a net profit of \$2,000. The two new agents have a net loss of \$1,000 each. To recoup their losses, the two new agents each sell a dealership to two more agents, introducing four new agents in total. The three old agents each now show a profit individually and a net total profit of \$4,000; the four new agents show a loss totaling \$4,000. At the n th stage 2^n new agents are sold dealerships. The $2^n - 1$ old agents from stages $1, \dots, n - 1$, have a total profit of $\$2^n \times 1,000$. The 2^n new agents a total loss of $\$2^n \times 1,000$. See Figure 11.3. The scheme proceeds in this way.

New agents enter, willing to pay their \$1,000 for the certainty of regaining \$2,000 in the next stage. This is where the scheme becomes a scam. The profit of each new level of agents can be secured only if the pyramid of agents can be allowed to grow exponentially and with it a huge, exponentially growing debt in the form of losses of agents on the newest level. The scheme collapses in debt as the exponential growth rapidly exhausts the pool of new agents willing to join.

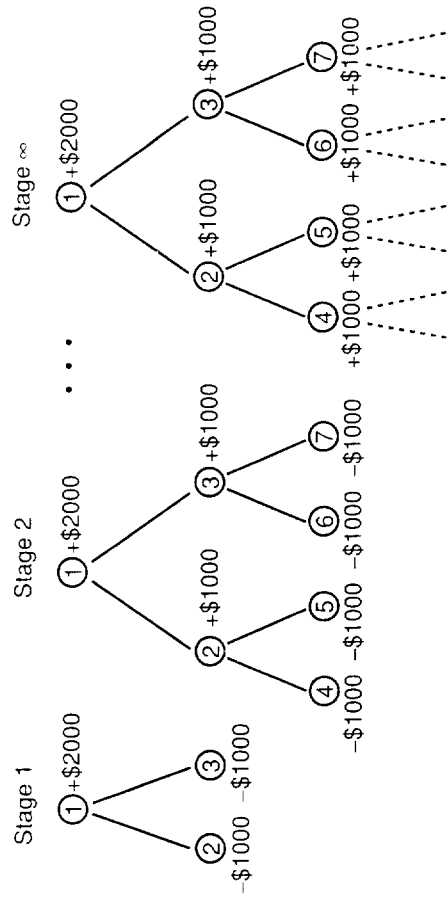

Figure 11.3 Pyramid marketing scam

Consider, however, what would happen if this pool were infinitely large and if the addition of new agents is accelerated so that the infinite pyramid is completed in finite time as a supertask. As the stages forming the pyramid proceed, the total debt will balloon without limit. Yet at the completion of the pyramid, the total debt would evaporate. Each agent in the pyramid would now show a net profit, for each would have recouped his loss in recruiting two more agents. The debt evaporation is the result eagerly foreseen in the propaganda used to recruit new, honest agents, who must only be convinced that the availability of a very large pool of agents is somehow close enough to an infinite pool for the evaporation to be realized.⁸ The naturalness of the evaporation is precisely what enables these schemes to flourish.

7 Black's Transfer Machine

While continuity of world lines allowed escape from Ross' paradox, in this case, it becomes the sticking point.⁹ Imagine two trays, one on the left ("L") and one on the right ("R"), which may move further apart from one another as time goes on but which may not come closer to one another than some finite distance.¹⁰ Starting at 11:59 PM a marble is shuttled back and forth between the two according to the following schedule:

Stage	Operation	Time of completion
1	Move the marble from L to R	11:59.5 PM
2	Move the marble from R to L	11:59.75 PM
3	Move the marble from L to R	11:59.875 PM
etc.	etc.	etc.

There are various ways to try to show that an antinomy results from this schedule. The analogy to the Thomson lamp is obvious (substitute L for ON and R for OFF), so those arguments of section 4 could be rehearsed in suitably translated form. Black gave an argument with a novel twist. In its most elementary form, it exploits symmetries in the sequence of transfers. Assume that the sequence of transfers indicated above results in the marble resting in some definite tray at 12:00 PM, say, the right tray:

$$R, L, R, L, R, L, \dots \rightarrow R$$

Since the trays are alike, this operation is the mirror image of the

sequence of transfers which begins with the marble in the right tray and which therefore must result in a marble in the left tray at 12:00 PM:

$$L, R, L, R, L, R, \dots \rightarrow L.$$

The outcome of the first series of exchanges would surely be unchanged if we began with the second stage, so that the marble began in the right tray and was first moved left. But then the sequence of transfers would be identical with the second sequence (excepting minor alterations in timing) and that sequence results in a marble in the left tray, contradiction!

As with the other examples, this contradiction can be resolved without us having to renounce the logical possibility of a supertask. The resolution is essentially Benacerraf's resolution of the Thomson lamp. All Black's argument shows is that the history of transfers prior to 12:00 PM cannot determine the position of the marble at 12:00 PM. The arguments that yield a contradiction are merely *reductio* demonstrations of the untenability of assuming otherwise.

However, this example is more perplexing than the ones we have seen so far. Black (1951-52) suggested that the completion of an infinite number of transfers is impossible on the grounds that the ball "would be committed to performing a motion that was discontinuous and therefore impossible" (p.81). On Black's behalf, we can put the argument this way. To resolve Ross' paradox we invoked continuity in the form of the postulate that the world line of a particle must be continuous. But sauce for the goose is sauce for the gander. So applying the world line postulate to the transfer machine we get the conclusion that at 12:00 PM the marble cannot be in the L tray, nor can it be in the R tray. But the ball has to be someplace. Contradiction.

Moreover, it may seem useless to try to use Newtonian mechanics to dissolve this paradox, for the marble's velocity increases without limit, as does the kinetic energy that must be supplied to enable its motion. Yet, it has been proven that Newtonian mechanics allows a closely related infinite transfer for idealized point mass particles! Consider four point mass particles confined to a line in Euclidean space. When the particles have positive separation they are assumed to interact via Newton's $1/r^2$ law. If there is a binary collision the singularity is regularized on the model of the elastic bounce. If there is a triple collision the solution ceases to exist. Mather and McGehee (1975) established that there is a non-empty set of initial conditions for the particles such that as $t \rightarrow 12:00$ PM, the particle positions obey the following conditions: $x_1(t) \rightarrow -\infty$, $x_2(t)$, $x_3(t) \rightarrow +\infty$, and the coordinate

$x_2(t)$ of the messenger particle passes through 0 an infinite number of times, each time covering a larger distance than before, because it bounces back and forth an infinite number of times between binary collisions with particles 1 and 3. At 12:00 PM positions are no longer specified for the four particles. They have, so to speak, escaped to infinity.

In a sense these particles violate world line continuity, but it is important to be clear about what this sense is. There is no violation of the basic postulate — used above in our resolution of Ross' paradox and assumed routinely in classical physics — that world lines of particles do not have breaks or endpoints. But there is a violation of the condition that the position of a particle at any instant can be obtained by taking the limit of its position at t as t approaches the instant in question; for at 12:00 PM the limits of the positions of the Mather—McGhee particles diverge. In the case of particles 1, 3 and 4, we have a ready answer to the question of where the particles went: 1 went to negative infinity; 3 and 4 went to positive infinity. But these infinities are not *bona fide* places in space. The notion that the particle 3 is “at spatial infinity” is an intuitively comforting fable that cannot bear scrutiny. By the same reasoning, particle 2 would have to be at *both* positive and negative infinity at 12:00 PM. The correct answer to where are the particles at 12:00 PM is that their positions are indeterminate, or, more precisely, that the second condition of world line continuity fails to specify them. In this regard they are exactly akin to the position of the marble in Black's transfer machine at 12:00 PM. Further, particle 2 has mimicked the marble in so far as it has crossed the origin infinitely often in a finite time.

In the version of Black's transfer machine where the particle is confined to a finite box there is a violation of a third condition of continuity, which states that if γ is a world line of a particle satisfying the basic continuity postulate (no breaks or end points) then γ is not trapped in a compact set K of spacetime, i.e. if γ enters K it must reemerge. It is worth noting that this requirement can be violated in general relativistic spacetimes even for a geodesic γ (see Hawking and Ellis, 1973 for examples). But the price to be paid for the violation is the presence of “almost closed” causal curves (in the form of a violation of strong causality — see Hawking and Ellis 1973, p. 195). This leads one to wonder whether in Newtonian mechanics $1/r^2$ interactions for point mass particles can be used to violate the no trapping condition, say, by having the particles spiral around each other at an ever faster rate. We think that the answer is negative since we conjecture that in order to have a non-collision singularity of Newton's equations for $1/r^2$ interactions at least one of the particles must escape to infinity.

8 The Pervasive Persuasiveness of Supertask Paradoxes

The supertasks we have examined here are representative of the types of supertask paradoxes presently in the literature. They point to the same moral. The contradictions that inhere in them do not arise from any intrinsic impossibility of supertasks. Each contradiction can be removed by careful excision of fallacies or unwarranted assumptions in a way that leaves the possibility of supertasks intact. In this analysis some further patterns begin to form. In particular, there is one major fallacy which appears to contribute materially to the seductiveness of supertask paradoxes.

We can conceive of the time development of a supertask as effected by a sequence of operations that carry us from one stage to the next. Any finite stage results from a finite composition of these operations. The final stage results from an infinite composition. Now it is a commonplace of mathematics that finite and infinite compositions differ in their properties (e.g. a finite intersection of open sets always yields an open set; but an infinite intersection of open sets can yield a closed set). Thus if some property is preserved at any finite stage of the supertask, that is no guarantee that it will be preserved in the transition to the infinite stage. Many of the trouble-making assumptions that we eliminated in analyzing the supertasks can be introduced exactly by this illegitimate projection. We take properties preserved as we step from finite to finite stage and illicitly assume they will be preserved in the transition to the final, infinite stage.

In the Dichotomy, for example, we saw a confusion of two senses of complete. At any finite stage, the two senses coincide. They fail to do so, however, in the infinite stage. In Thomson's lamp, at any finite stage the setting of the lamp is fixed by the history of switching; it fails to be at the infinite stage. In Ross's paradox, the condition of number count continuity obtains at any finite stage. It can fail at the infinite stage. Finally in Black's transfer machine, the marble's position is determined by its prior history at any finite stage; it fails to be at the infinite stage. Once these assumptions are made explicit, we become less likely to project them illicitly. While they remain tacit, as is usually the case, the projection is easy to fall into.

Many paradoxes of the infinite depend upon the ease with which we fall into projecting incorrectly properties from finite to infinite composition. The “proof” that $2 = \pi$ is a classic example from the paradox literature (see Northrup 1971, pp. 135–6). Consider the straight line segment AB of unit length of Figure 11.4. We can approximate it somewhat clumsily by a semicircular arc C_1 . We can improve the

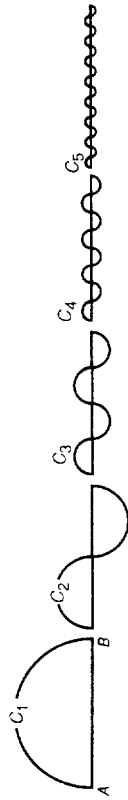

Figure 11.4 “Proof” that $2 = \pi$

approximation by an operation which replaces the arc C_1 by two connected semicircular arcs to yield C_2 . The operation can be repeated indefinitely as indicated yielding arcs C_3, C_4, \dots until, in the limit, the arc C_n will consist of a set of points that coincides exactly with AB .

Now the fallacious inference: the curves of family C_1, C_2, \dots approximate the interval AB better and better, achieving coincidence in the limit. Therefore the lengths of the curves C_1, C_2, \dots must approach the length of AB in the limit. Elementary geometry however tells us that the length of each semicircular arc is just $\pi/2$ times that part of the interval AB that the arc spans. It now follows that all of C_1, C_2, \dots have the same length:

$$\text{Length } C_1 = \text{Length } C_2 = \text{Length } C_3 = \text{Length } C_4 = \dots = \pi/2$$

so that if we insist that the limiting length of C_1, C_2, \dots is equal to the unit length of AB we arrive at the “result” $2 = \pi$.

The problem concerns the operation that replaces a semicircular arc with two connected semicircular arcs. Under this operation, the length of the curve is preserved. Under *finitely* many of these operations the length of the curve is preserved. But under *infinitely* many, the length of the curve is not preserved. To understand why, we recall that the length of a curve is not fixed directly by the locus of the curve, but by an integration over the tangent vectors to the curve. The locus of C_1, C_2, \dots approach AB in the limit. But the tangents to C_1, C_2, \dots do not approach the tangent vectors of AB in the limit. As it turns out, this limit is undefined. Therefore we have no basis for expecting the limit of the lengths of C_1, C_2, \dots to approach AB .¹¹

9 Supertasks and Infinite Computation

Black and Wisdom were not alone in their willingness to draw conclusions about the continuum from a contemplation of supertasks. They were preceded by the distinguished mathematician and physicist, Hermann Weyl. In a remarkable passage in *Philosophy of Mathematics*

and *Natural Science*, Weyl (1949) also drew infinite computation into the web of supertasks:

If the segment of length 1 really consists of infinitely many subsegments of length $1/2, 1/4, 1/8, \dots$ as “chopped-off” wholes, then it is incompatible with the character of the infinite as “incompletable” that Achilles should have been able to traverse it all. If one admits this possibility, then there is no reason why a machine should not be capable of completing an infinite sequence of distinct acts of decision within a finite amount of time; say, by supplying the first result after $1/2$ minute, the second after $1/4$ minute, the third $1/8$ minute later than the second, etc. In this way it would be possible, provided the receptive power of the brain would function similarly, to achieve a traversal of all the natural numbers and thereby a sure yes-or-no decision regarding any existential question about natural numbers! (1949, p. 42)

The exclamation point indicates a silent *modus tollens*. Weyl seeks to use the presumed impossibility of the traversal of all natural numbers to reject the notion that a segment of length 1 really consists of infinitely many “chopped-off” wholes. We shall return shortly to the broader views behind Weyl’s remarks.

Clearly we see no problem in either the infinite traversal of the natural numbers of Zeno’s runner completing his run, even if a unit length is conceived as composed of infinitely many parts. The possibility of a traversal of all natural numbers has implications for the philosophy of mathematics, as noted by Benacerraf and Putnam in their introduction to *The Philosophy of Mathematics*:

If we take the stand that “non-constructive” procedures – i.e. procedures that require us to perform infinitely many operations in a finite time – are conceivable... then we can say that there does “in principle” exist a verification/refutation procedure for number theory... [and hence that] the notion of “truth” in number theory is not a dubious one. (1989, p. 20)

In the remainder of the paper, we will try to put flesh on the bones of the idea that a supertask may be used to generate a decision procedure for number theory and then try to understand some of its consequences.

10 Bifurcated Supertasks in Relativistic Spacetimes

The core of our infinite computing machines are bifurcated supertasks. One part – the Slave – consists of a computer which can devote infinite

time to a computation that need not halt after finitely many steps. The Slave computer may, for example, run through all quadruples of integers (x, y, z, n) seeking a quadruple with $n > 2$ for which $x^n + y^n = z^n$. The second component is an external observer – the Master – who has causal access to the entire slave computer’s history but experiences only a finite lapse of time. If, for example, the Slave computer agrees to signal the Master if a quadruple satisfying $x^n + y^n = z^n$ ($n > 2$) is found, then upon receiving a signal the Master will know that Fermat’s last theorem (“FLT”) is false. If the Master receives no signal, then she will know after a finite time that the theorem is true.

But is it really possible for a Master to profit from the infinite labors of a Slave? Relativistic spacetimes provide a context for realizing such possibilities and their pursuit leads one to some of the most interesting foundations problems in general relativity.

Pictured in Figure 11.5 are two timelike half-curves¹² γ_S and γ_M in Minkowski spacetime. The Slave γ_S undergoes constant (“Born”) acceleration, and as a result $\int \gamma_S dt = \infty$.¹³ The Master contrives to accelerate in such a way she keeps the Slave in her causal shadow – $I(\gamma_M) \supset \gamma_S$ – and such that she ages only a finite amount since $\int \gamma_M dt < \infty$.¹⁵ For this it suffices that the Master accelerate so that her proper time is related to coordinate time t by $dt = \exp(-t)dt$.

There are two sorts of problems with this scenario, some physical, some conceptual. In the former category, there is the fact that the total

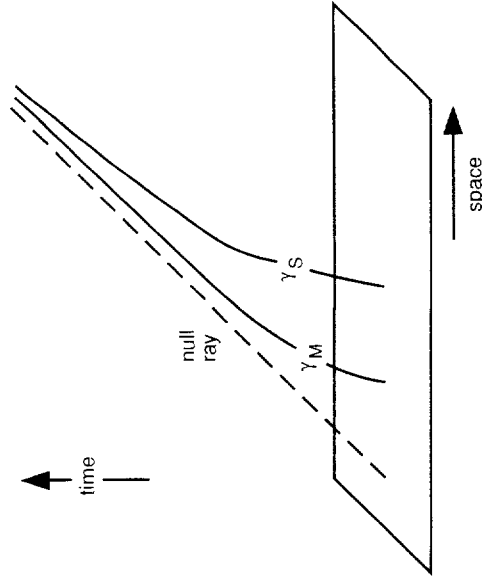

Figure 11.5 Slave and Master in Minkowski Spacetime

integrated acceleration of γ_S is infinite, which means that if the Slave tries to accomplish his journey by means of a rocket ship, an infinite fuel-to-payload ratio would be required.¹⁶ Then there is the fact that γ_M experiences unbounded acceleration and, thus, any physical embodiment of the Master would eventually be crushed to death by g-forces. But even leaving aside such problems about physical realizations of γ_M and γ_S , there is the conceptual objection that at no point on her world line does the Master have direct causal access to all of the labors of her Slave. Thus, if FLT is true, there is no definite moment at which the Master can be said to have attained knowledge of the truth of FLT as a result of the Slave’s labors.

This last objection suggests that in order to have a successful bifurcated computing machine, the above construction has to be modified so that there is a $p \in \gamma_M$ such that $I(p) \supset \gamma_S$. That is, the entire world line of the Slave is contained within the chronological past of a single event on the Master’s world line. From that event on the Master can know the outcome of the Slave’s infinite labors. Such a construction cannot be done in Minkowski spacetime. But it can be done in some general relativistic spacetime which we have dubbed *Malament–Hogarth* spacetimes (see Earman and Norton, 1993). Some of these spacetimes also escape the above worries about physical embodiment of the Master and Slave since their world lines can be chosen to be geodesics, that is, world lines of free fall.

The reader who is suspicious that this is too good to be true is right to be suspicious. Some Malament–Hogarth spacetimes involve acausal features; for example, they allow an observer to travel into his own past, raising worries such as the “grandfather paradox.” (What if the observer traveled into his distant past and shot his grandfather before grandpa became a father?¹⁷) Other Malament–Hogarth spacetimes are causally nice¹⁸ but they all involve nasty effects such as divergent blue-shifts, indicating a kind of instability (see Earman and Norton, 1993). Malament–Hogarth spacetimes violate Roger Penrose’s cosmic censorship hypothesis which holds that general relativity contains mechanisms to prevent the occurrence of “naked singularities.” The validity of this hypothesis has been called the most important unresolved problem in classical general relativity (see Earman, 1994b for a discussion). In this way philosophical concerns about supertasks are linked to important research problems in physics.

Does this mean that in trying to pull off bifurcated supertasks in general relativistic spacetimes we have simply traded worries about doing an infinite number of tasks in a finite amount of time for worries about spacetime structure? Even if that is all we have accomplished, it still seems to us a non-trivial accomplishment. As we have seen, there is

a longstanding philosophical tradition to the effect that supertasks are logically or conceptually impossible. Bifurcated supertasks are surely neither since they use mathematically well-defined spacetimes. But additionally these spacetimes are more than mere conceptual possibilities. Among them are ones that satisfy Einstein's field equations of gravitation and standard energy conditions (guaranteeing, for example, non-negative energy densities). Though such spacetimes are problematic in various ways, they are, we contend, not beyond the pale of physical possibility. If the Creator had a taste for the bizarre we might find that we are inhabiting one of them.

11 Simple Infinity Machines

There is a clear moral in our earlier analysis of supertask paradoxes. While relativistic spacetimes provide a consistent arena for bifurcated supertasks, they cannot protect us from paradox if we insist on assuming impossible properties for machines that execute the supertasks. Indeed infinite computing machines must resort to a device like a bifurcated supertask exactly to avoid such paradoxes. Thomson (1954–55, p. 95) already foreshadowed what may happen otherwise. If we assume a super computer able to complete an infinity of computations and then continue as normal, nothing would prevent it computing the complete decimal expansion of π and, as each decimal was generated, setting a register according to its parity. When the computation was complete, that register would indicate the parity of the last digit of π – and paradoxically so, since there is no last digit!

If further such paradoxes are to be avoided, we must carefully specify precisely what our super computer is assumed capable of doing. To this end we introduce what is intended to be the simplest use of a bifurcated supertask in computation. In particular, it will exploit just one supertask. (We shall return briefly to cases of machines that exploit compounded supertasks, once the properties of the simple case have been investigated.) A *simple infinity machine* is just a Turing machine that is allowed to complete a countable infinity of steps and comprises the Slave part of the bifurcated supertask; the outcome of the calculation is read by the Master through signals from the Slave. The extra power of the machine derives solely from the fact that failure of the Slave Turing machine to halt is no longer uninformative. It no longer means that the machine is either about to halt or will never halt. In a simple infinity machine, it means the latter.

There are only two means available for the Slave to signal results to the Master. It may report them as:

- 1 A signal that the machine has halted after finitely many steps and (optionally) the signal may contain the code number of an output. (This is the usual output of an ordinary Turing machine on halting.)
- 2 A failure to halt, which the Master will recognize from the lack of transmission of the signal of (1).

We must rule out stronger possibilities, at least in the first case, on pain of paradox:

- The Slave cannot leave a tape for inspection by the Master as output. Otherwise, if the Slave program simply alternates 0 and 1 indefinitely in some cell, then the final state of the cell fails to reflect the limiting result of the computation – since there is no limit.¹⁹ To assume otherwise reproduces the Thomson lamp paradox. Known examples of Malament–Hogarth spacetimes automatically implement this form of censorship. They do not permit survival of the Slave's tape, sending the tape falling into a spacetime singularity or off to infinity.
- The Master may not infer results of computation by reading the limiting behavior of an infinite sequence of signals emitted by the Slave in the course of computation. To assume otherwise would violate the assumption that a simple infinity machine exploits just one supertask, for the reading of the infinite sequence of signals by the Master amounts to a second supertask.

While we do not admit it for a simple infinity machine, we should not be too hasty in judging the reading of an infinite sequence of signals as inherently paradoxical. We may avoid paradox if we are modest in our assumptions over what the reader could do. It could accommodate an infinitely alternating sequence of signals, 0, 1, 0, 1, ... without Thomson lamp paradoxes if it could sense the failure to converge of such a sequence.²⁰ However, this escape may be short lived. It may well be that the idealizations needed to admit such convergence sensing devices will also admit paradoxical consequences. For example, if the resources are sufficient to allow the device to store the latest signal in a register that faithfully records, then we do recreate a Thomson lamp paradox.

12 The Power of a Simple Infinity Machine

A simple infinity machine can decide the truth of any proposition of number theory that is purely existentially or purely universally quantified in prenex normal form, where the relation quantified over is

recursive. Its Slave simply checks the relation in the scope of the quantifiers sequentially for all values of its arguments, looking for a counterexample of the former or for a verifier for the latter. Thus Fermat's last theorem, whose status at the time of writing remains unresolved, would succumb to a simple infinity machine, since it has the prenex normal form $(\forall x)(\forall y)(\forall z)(\forall n) \neg F(x, y, z, n)$ and F is recursive.

Of course, even if Fermat's last theorem is verified as true, this does not settle the status of its theoremhood in your favorite axiomatization of arithmetic. But this too can be resolved by a simple infinity machine, which can be used to check whether an arbitrarily given integer n is a member of a recursively enumerable (r.e.) set of integers. Thus, Church's theorem notwithstanding, it would seem that a simple infinity machine can be used to check for theoremhood in anything that deserves to be called a formal system, a system for which there is a recursive method for determining whether a sequence of formulas constitutes a proof and, hence, for which the theorems are r.e. Applying this to your favorite system of formal arithmetic, if it was found that neither FLT nor $\neg FLT$ is a theorem, we would have a mathematically interesting example of Gödel incompleteness.

It may well seem that a simple infinity machine is capable of overcoming all the usual barriers to computation. The celebrated halting problem, for example, succumbs. A simple infinity machine can simulate the behavior of any Turing machine on any input and decide whether it will halt or not. However simple infinity machines turn out only to carve off the smallest slice of the great turkey of the uncomputable. This is already suggested if we attempt to decide propositions with mixed quantifiers. Consider, for example, the proposition that there is some ultimate number n that stands in (recursive) relation R to all numbers. That is, $(\exists n)(\forall x)R(n, x)$. A simple infinity machine may seek to decide this proposition by sequentially checking each n . For each n , it proceeds to run through values of x , computing $R(n, x)$, until a falsifier is found, whereupon it moves on to the next value of n . This program fails since the failure of the program to halt will be ambiguous. It may either mean that the Slave has found the ultimate number and is running through all values of x ; or it may mean that no ultimate number is found and the machine is trapped in checking unsuccessfully the infinite candidate values for n . The Master has no way to decide which.

Since the procedure sketched is just one of infinitely many that we could employ to decide $(\exists n)(\forall x)R(n, x)$, we may well wonder if its failure to decide such propositions derives from our incompetence or lack of imagination at programming simple infinity machines at this type of task. We can quickly convince ourselves that this is not so in so far as "most" (in a natural sense) Turing uncomputable tasks remain uncomputable for simple infinity machines. To see this, consider a family

of propositions $S(z) = (\exists x)(\forall y)R(x, y, z)$ in number theory, where R is a recursive relation. It turns out that there are R s such that no simple infinity machine can decide the truth of an arbitrary sentence of that corresponding family $S(0), S(1), \dots$. To see this assume otherwise. That is, assume that there is a simple infinity machine that can decide the truth of $S(z)$ for any value of z . In accord with our earlier discussion, if the simple infinity machine is to succeed, its Slave Turing program must perform one of the following four ways:

- (a) for all z , the program halts finitely;
- (b) for all z , failure to halt means that $S(z)$ is false;
- (c) for all z , failure to halt means that $S(z)$ is true;
- (d) for some z , failure to halt means that $S(z)$ is true and, for some z , failure to halt means that $S(z)$ is false.

In case (d), the meaning of failure to halt must be finitely computable for each z . That is, the set of all numbers z must be recursively divisible into two sets such that if the program fails to halt on input z , then, if z lies in the first set, $S(z)$ is false and, if z lies in the second set, $S(z)$ is true. Otherwise failure to halt of the Slave program cannot be interpreted unambiguously by the Master, so that the simple infinity machine would fail to decide $S(z)$ for all z .²¹

In case (a), the formula $S(z)$ will be expressible as $S_n(z) = R_n(z)$ where R_n is a recursive predicate.

In case (b), the Slave program is guaranteed to halt only when $S(z)$ is true. That is, when $S(z)$ is true, a halting condition is satisfied in a finite number of steps. The satisfaction of the halting condition appears most generally as the confirmation that some recursive relation

$R'(u, u', \dots, z)$ is satisfied for some values of u, u', \dots , so that $S(z)$ will have the general form

$(\exists u)(\exists u') \dots R'(u, u', \dots, z)$. Projecting the tuple

(u, u', \dots) onto a unique single number by the usual methods,

we find that $S(z)$ is expressible as $S_k(z) = (\exists y)R_k(y, z)$ for some recursive relation R_k .

In case (c), the Slave program is guaranteed to halt only when $S(z)$ is false, that is, when $\neg S(z)$ is true. It follows similarly to case (b) that $\neg S(z)$ can be expressed by $(\exists x)R'(x, z)$ for some recursive relation R' . Setting $R_c = \neg R'$ we have that $S(z)$ can be expressed as $S_c(z) = S_c(z) = (\forall x)R_c(x, z)$.

In case (d), $S(z)$ will be expressible by sentences of the forms $S_k(z)$ or $S_c(z)$ according as to whether z lies in the set in which the failure to halt of the Slave machine means that $S(z)$ is false or $S(z)$ is true. It

follows that $S(z)$ is expressible as $S_d(z) = [(\exists y)R_{d1}(y, z) \vee (\forall x)R_{d2}(x, z)]$ where R_{d1} and R_{d2} are recursive relations. We have assumed that it can be decided finitely for each z which of the two sets it lies in. In forming $S_d(z)$, we assume that the code that decides this is incorporated into the Turing machines computing the relations R_{d1} and R_{d2} so that each machine will only seek to verify that it is satisfied by z if z is of the appropriate type.²²

The final result follows immediately from the result that there is a recursive relation R such that the corresponding family of sentences $S(z) = (\exists x)(\forall y)R(x, y, z)$ cannot be expressed in any of the forms $S_a(z)$, $S_b(z)$, $S_c(z)$, or $S_d(z)$.²³ Therefore, in these cases, no simple infinity machine can decide the truth of the family of sentences $S(z)$.²⁴

While this limitation to the power of simple infinity machines is severe, it can be broken if we are prepared to set infinitely many simple infinity machines to a task – and even infinite hierarchies of such machines. For example $(\exists n)(\forall x)R(n, x)$ could be decided if we set infinitely many simple infinity machines to decide the infinitely many propositions $(\forall x)R(1, x)$, $(\forall x)R(2, x)$, \dots and collected the results with another infinity machine. These prospects have been investigated by Hogarth (1994), who finds that the infinitely bifurcated supertasks required can be realized in relativistic spacetimes.

13 Implications for the Philosophy of Mathematics

As we mentioned, Benacerraf and Putnam (1989) held that if it is conceptually possible to perform an infinite number of operations in a finite time, then there is a verification/refutation procedure for arithmetic,²⁵ and, hence, the notion of truth in arithmetic cannot be held to be dubious. The problem is that this conditional has little polemical force; for those intuitionists whose scruples make them dubious about truth are precisely those who deny the conceptual coherence of completing an infinite series of acts. Weyl is a prime example.

The remarks we quoted earlier from Weyl's magisterial *Philosophy of Mathematics and Natural Science* are but a fragment of a finitism that pervades his philosophical writing. His skepticism about an infinity machine that could decide any existential question in number theory was not a reflection of the uncomputability of certain tasks. His words were first published in 1927 prior to the work of Church, Turing and others on uncomputability.²⁶ Rather his core claim is that arithmetic assertions are not meaningful if their truth conditions require the complete running through of an infinite sequence of numbers. Thus, considering some freely chosen sequence of numbers, he insisted that

statements concerning this sequence have meaning only if their truth can be decided at a finite stage of the development. For example, we may ask if the number 1 occurs among the numbers of the sequence up to the 10th stage, but not whether 1 occurs at all, since the sequence never reaches completion. (Weyl, 1932, p. 66)

What justifies this claim and claims like it?²⁷ according to Weyl, is that they “spring from the nature of the infinite” (1932, p. 73). Here he presumably refers to the “the essence of the infinite, the ‘incomplete’” (1932, p. 59). Thus, where we may be untroubled to think of an infinity machine deciding Fermat's last theorem, Weyl held that

mathematics owes its greatness precisely to the fact that in nearly all its theorems what is essentially *infinite* is given finite resolution. . . . “Fermat's last theorem,” is intrinsically meaningful and either true or false. But I cannot rule on its truth or falsity by employing a systematic procedure for sequentially inserting all numbers in both sides of Fermat's equation. Even though, viewed in this light, this task is infinite, it will be reduced to a finite one by the mathematical proof (which, of course, in this notorious case, still eludes us.) (1994, p. 48)

These finitist scruples extend to his treatment of the continuum. The reals are to be constructed by finitist methods, essentially using Dedekind cuts, and he rejected the conception of the continuum as composed of the infinitely many “chopped off wholes” of the Zeno Dichotomy. (See also Weyl (1932, p. 59; 1994, Chapter 2).) In sum, Weyl abandons the “infinite totality of numbers” as meaningless, as “a realm of absolute existences which is ‘not of this world’” (1929, p. 154).²⁸

We believe that the bifurcated infinity machines discussed in section 10 provide an effective response to Weyl. In the first place, the bifurcation obviates the need to perform a proper supertask, and it leaves Weyl and his fellow travelers free to think of the infinity of tasks assigned to the Slave as belonging to the uncompletable. The verification/falsification procedure comes not from completing an infinite number of checks in a finite time but in having direct causal access to the fruits of all of these acts. In the second place, as a leading proponent of and contributor to general relativity, Weyl was hardly in a position to claim that the spacetime structures needed to implement the bifurcated supertasks are not conceptually well-defined possibilities. Furthermore, in hindsight, Weyl might well have agreed that these spacetimes are more than mere conceptual possibilities. Weyl produced a family of axisymmetric solutions to Einstein's field equations, a subfamily of which is called the Curzon solution. Recently Scott and Szekeres (1986) constructed the

maximal extension of the monopole Curzon solution, which turns out to contain a ring-like singularity. Some of the timelike half curves that terminate on the singularity have infinite proper length. We conjecture that there are spacetime points p such that $I(p)$ contains such curves. If so, this spacetime supports bifurcated supertasks.

It may seem extraordinary that facts about spacetime structure can have implications for the concept of truth in mathematics. We too think that this is extraordinary – so much so that we would prefer to say that what has been learned is not something about the concept of truth but about the implausibility of certain philosophical scruples about truth.

Do bifurcated supertasks have implications for Church's thesis (or better, proposal) that effective/mechanical computability is to be identified with recursiveness or Turing computability? Our answer is: some but no profound ones. In the context of bifurcated supertasks, Church's proposal is most plausibly construed as applying to what the Slave machine can do, the thesis being that Turing computability serves as an upper bound for any such machine.²⁹ (It is an upper bound because no actual machine has an unlimited memory storage or unlimited computing time. Nor can the machine be speeded up indefinitely without violating the relativistic prohibition against superluminal velocities.) This proposal is not unchallengeable – indeed, one of us thinks that there are successful challenges³⁰ – but that is a matter to be reserved for another occasion. The relevant point here is that realizability of simple infinity machines in general relativistic spacetimes is compatible with any account of effective/mechanical computability for the Slave machine. Then, given an account – Church's or other – that implies that some sets of integers are effectively/mechanically enumerable but not effectively/mechanically decidable, the Slave–Master arrangement in Malament–Hogarth spacetimes provides a procedure that plausibly can be said to outdo effectively/mechanically decide membership in the set and thus to outdo any Turing machine. But the core of Church's proposal, as we have construed it, remains untouched.

14 Conclusion

The discussion of the paradoxical infinity machines has led to some interesting facets of motion in a Newtonian setting. But as far as we can tell, such machines have nothing new to teach us about the nature of infinities or the continuum. This may be a little disappointing but it is hardly surprising. Over the centuries paradoxes of infinity have played an honorable role in pointing to fundamental questions in logic, mathematics, and the physics of motion. That they no longer have the

power to generate new knowledge is due to the fact that they have fulfilled the function of good paradoxes all too well.

We are not so naive as to think that we have had the last word on supertasks. Since it is the business of philosophers to uncover logical and conceptual difficulties, we would not be surprised if there were to be continued assertions that supertasks are by their very nature contradictory, paradoxical, or puzzling – not surprised, but certainly disappointed. We take it as established as clearly as anything can be in this area that some non-trivial supertasks are unproblematic. Others are paradoxical in the proper sense of that word. But they are not paradoxical because of any inherent incoherence in the notion of a supertask. To assume otherwise is to preclude consideration of conceptual devices that have most interesting consequences in areas that transcend the simple domain of lamps and urns. The infinite computing machines of Malament–Hogarth spacetimes may well just be one example.

Notes

We are grateful to Ulrich Maier, Robert Nola, and Wesley Salmon for helpful discussion. John Earman would like to take the liberty of mentioning that during his junior year at Princeton, Paul Benacerraf handed him a reprint of his just published article "Tasks, Super-Tasks, and Modern Eleatics" (1962). It has taken him a third of a century to make (what he hopes is) an advance on this article.

- 1 In his review of Zeno's paradoxes, Salmon (1970, pp. 9–10) considers a second form of the dichotomy according to which the runner cannot even get started. He must first run to the half way point, but before that he must run half way to the half way point and so on indefinitely. The original form of the dichotomy is essentially equivalent to the "Achilles" paradox of Zeno according to which the faster runner cannot overtake the slower. The faster would first have to run to the place the slower had just left, and then to the place to which the slower had moved and so on indefinitely.
- 2 For further discussion, see Vlastos (1967, pp. 372–4).
- 3 This assumes that the runner's hands don't "fly off to spatial infinity," an assumption that is plausible if they remain attached to his body and don't stretch beyond all bounds. The relevance of this caveat will emerge below.
- 4 Thomson (1954–55). For critical discussions, see Benacerraf (1962), Chihara (1965), and Grünbaum (1969, 1970).
- 5 Thus Grünbaum (1970, pp. 239–40), at Al Janis' suggestion, describes a switching mechanism in which the lamp state depends on the direction of approach of a pointer that executes infinitely many oscillations about a mid point in a finite time, ending, let us say, at 12:00 PM. The direction of approach is undefined at 12:00 PM and the directions prior approach no limit. Therefore no consistent mechanism can continue faithfully to set the

lamp state from the direction of approach at 12:00 PM, either by using the direction immediately prior or projecting it via the persistence property. Any attempt to construct such a mechanism will either fail (but possibly remain consistent) or be wracked with inconsistency.

- 6 This paradox is due to Ross (1988). It is discussed in Allis and Koetsier (1991), van Bendegem (1994) and Hofgate (1994).
- 7 Maintaining the continuity of the number function instead would require forfeiting of this simple spacetime picture. It would be an interesting exercise to devise a kinematics of ball transfers that would allow the number condition to be maintained. It may prove incompatible with the numbering scheme used for the balls, unless the identity of the balls cannot be maintained or unless a plausible mechanism for generating new balls can be built in, for none of the original numbered balls can remain in the vase at 12:00 PM. This calls to mind the failure of world line continuity to be explored in Black's transfer machine below. We also think of the particles of quantum field theory for they are not conserved and need not retain their individual identities in the course of interactions.
- 8 Of course the dishonest agents need only be convinced that their stage is sufficiently remote from the stage at which the scheme collapses!
- 9 This machine was introduced by Black (1950–51). It is discussed by Grünbaum (1970, p. 240).
- 10 This precludes a less interesting variant of the paradox in which the diances covered by the marble in each transfer diminish to zero, just as do the successive bounces of the bouncing ball.
- 11 To see this in more detail, describe a curve in the usual manner as some function $y(x)$ in a Euclidean space with Cartesian coordinates (x, y) . The functions $y_1(x), y_2(x), \dots$ that correspond to C_1, C_2, \dots do approach the function $y_{AB}(x)$ that corresponds to AB in the limit. However the length of each curve is not given directly as a function of $x(x)$; it is given as a function of the derivative $y'(x) = dy(x)/dx$; that is, the length is $\int \sqrt{1 + y'^2(x)} dx$. But the derivatives $y'_1(x), y'_2(x), \dots$ do not approach the derivative $y'_{AB}(x)$ in the limit. It follows that the lengths of C_1, C_2, \dots need not approach that of AB in the limit.
- 12 A timelike half-curve is a timelike curve which has a past endpoint and which is extended as far as possible in the future direction.
- 13 Here τ stands for proper time.
- 14 For a spacetime point p , $I(p)$ denotes the chronological past of p , i.e. the set of all points q such that there is a non-trivial future directed timelike curve from q to p . If X is a set of spacetime points, $I(X) = \cup_{p \in X} I(p)$.
- 15 This assumes that biological aging is proportional to proper time.
- 16 The total acceleration $TA(\gamma)$ of γ is defined to be $TA(\gamma) = \int_a^b \alpha dt$, where α is the magnitude of the four-acceleration of γ . If m_t and m_{fuel} are respectively the final mass of the rocket and the mass of the fuel expended, then even assuming perfectly efficient rocket motors, a rocket propelled purely by its motors must satisfy (Malament 1985)

$$m_t/(m_t + m_{fuel}) \leq \exp(-TA(\gamma))$$

- 17 For an attempt to dispel the air of paradox here, see Earman (1994a).
- 18 At least they can satisfy what is called the condition of stable causality which implies that there is a global time function which increases along every future directed timelike curve (see Hawking and Ellis, 1973, p. 198). However, they cannot be causal in the sense of allowing for global Laplacian determinism; technically, they cannot be globally hyperbolic.
- 19 To assume that the Slave machine incorporates a device that inserts a special no-convergence code in the cell is to assume that the machine employs a second supertask, contrary to our assumption. This second supertask may also invite paradox: see below.
- 20 Such devices may be possible if we are prepared to admit sufficient idealizations, including infinitely fine discrimination in pointer readings. Consider, for example, a reader with a pointer scale from -1 to $+1$. The pointer starts at 1 and its position is reset to $\pm 1/2, \pm 1/4, \pm 1/8, \dots$ each time the data stream flips from 0 to 1 or from 1 to 0; the former flip resets to positive values and the latter flip to negative values. With the completion of the supertask, a positive pointer reading corresponds to a convergence to 1, a negative pointer reading to a convergence to 0, and a zero reading to a failure to converge.
- 21 Of course, in general in case (b) there will be some z for which $S(z)$ is false but whose falsity is determined in finitely many steps by the program. For such z , $S(z) = R'(z)$, for some recursive R' . This trivially has the existentially quantified form required since $R'(z)$ is equivalent to $(\exists y)(R'(z) \ \& \ (y = y))$. The Turing machine for R_{01} will only attempt to complete its calculation for those z in the set for which failure to halt entails that $S(z)$ is false. Similarly, the Turing machine for R_{0c} will only attempt to complete its calculation for those z in the set for which failure to halt entails that $S(z)$ is true.
- 22 This result follows from the structure of the Kleene arithmetic hierarchy (see Rogers, 1987, Chapter 14; Enderton, 1972, Chapter 3). The set of numbers that satisfies $S(z)$, $\{z: S(z)\}$, lies in Σ_2 of the hierarchy. Correspondingly, $\{z: S_c(z)\}$ lies in Σ_0 , $\{z: S_0(z)\}$ lies in Π_0 , and $\{z: S_d(z)\}$ lies in Π_1 . To see the last case, we need only add dummy variables to the sentence $S_d(z) = [(\exists y)R_{01}(y, z) \ \& \ (\forall x)R_{0c}(x, z)]$ to get it into the form $[(\forall x)(\exists y)(R_{01}(y, z) \ \& \ (x = x)) \ \& \ (\forall x)(\forall y)(\exists y)R_{0c}(x, z) \ \& \ (y = y)] = (\forall x)(\exists y)R_d(x, y, z)$ for a recursive relation R_d . Thus, $S_d(z)$ has the quantifier structure of " $\forall\exists$ " so the corresponding set lies in Π_2 . The core result for our purposes is that there are sets in Σ_2 that fail to lie in any of Σ_0 , Σ_1 , Π_1 , or Π_2 .
- 24 The arithmetic hierarchy gives a precise sense in which "most" Turing uncomputable tasks remain uncomputable for a simple infinity machine. The Σ_0 sets are recursive. Σ_1 sets are recursively enumerable. Simple infinity machines extend the power of Turing machines up just one level of the hierarchy in so far as they enable sets of Σ_1 to be decided. They fail to decide Σ_2 sets and higher in the hierarchy.
- 25 Subject, as we now must observe, to the restrictions mapped out in the last section. A simple infinity machine suffices to decide purely universal or purely existential propositions.

- 26 The same passage appears in the original German edition, Weyl (1921, p. 224).
- 27 Similar claims appeal elsewhere in his writings. Weyl (1971, p. 224) finds it meaningless to speak of running through all numbers to find if there is a prime of form $2^{2^{n+1}} + 1$. Elsewhere the simple existential claim "there exists an even number" is denounced on Brouwer's ever present authority as an "infinite logical summation" and "not a proposition in the proper sense that asserts a fact" (1949, p. 50). Correspondingly "All numbers are even" is an infinite logical product " \wedge is even, and 2 is even, and 3 is even ..." which "obviously has no meaning." (1929, p. 152.)
- 28 See also Weyl (1949, p. 38; 1932, pp. 62–3.) and (1932, p. 83) for the conclusion that "the completed, the actual infinite as a closed realm of absolute existence is not within its [the minds intuitive] reach."
- 29 This way of construing Church's thesis/proposal is to be found in Enderton (1972).
- 30 See Earman (1986); see also Pitowsky (1990).

References

- Allis, V. and Koetsier, T. 1991: "On Some Paradoxes of the Infinite," *British Journal for the Philosophy of Science* Vol. 42, pp. 187–94.
- Benacerraf, P. 1962: "Tasks, Super-Tasks, and Modern Eleatics," *Journal of Philosophy*, Vol. LIX, pp. 765–84. Reprinted in Salmon, 1970.
- Benacerraf, P. and Putnam, H. (eds.) 1989: *Philosophy of Mathematics: Selected Readings*, 2nd edition, Cambridge: Cambridge University Press.
- Black, M. 1950–51: "Achilles and the Tortoise," *Analysis*, Vol. XI, pp. 91–101. Reprinted in Salmon, 1970.
- Chihara, C. 1965: "On the Possibility of Completing an Infinite Task," *Philosophical Review*, Vol. LXXIV, pp. 74–87.
- Earman, J. 1986: *Primer on Determinism*, Dordrecht: D. Reidel.
- Earman, J. 1994a: "Recent Work on Time Travel," in S. Savitt (ed.) *Time's Arrow Today*, Cambridge: Cambridge University Press.
- Earman J. 1994b: *Bangs, Crunches, Shrieks, and Whimpers: Singularities and Acausality in Relativistic Spacetimes*, New York: Oxford University Press.
- Earman J. and Norton, J. D. 1993: "Forever Is a Day: Super-Tasks in Pitowsky and Malament-Hogarth Spacetimes," *Philosophy of Science*, Vol. 60, pp. 22–42.
- Enderton, H. B. 1972: *A Mathematical Introduction to Logic*, New York: Academic Press.
- Grünbaum, A. 1969: "Can an Infinitude of Operations be performed in a Finite Time?" *British Journal for the Philosophy of Science*, Vol. 20, 203–18.
- Grünbaum, A. 1970: "Modern Science and Zeno's Paradoxes of Motion," in Salmon, 1970, pp. 200–50.
- Hawking, S. W. and Ellis, G. F. R. 1973: *The Large Scale Structure of Space-Time*, Cambridge: Cambridge University Press.
- Hogarth, M. 1994: "Relativistic Non-Turing Computers and the Failure of Church's Thesis," pre print.
- Holgate, P. 1994: "Discussion: Mathematical Notes on Ross's paradox," *British Journal for the Philosophy of Science*, Vol. 45, pp. 302–4.
- Malament, D. 1985: "Minimal acceleration requirements for 'time travel' in Gödel space-time," *Journal of Mathematical Physics*, Vol. 26, pp. 774–7.
- Mather, J. N. and McGehee, R. 1975: "Solutions of the Collinear Four-Body Problem Which Become Unbounded in a Finite Time," in J. Moser (ed.), *Dynamical Systems, Theory and Applications*, New York: Springer-Verlag, pp. 573–97.
- Northrup, E. P. 1971: *Riddles in Mathematics*, Harmondsworth: Middlesex: Penguin.
- Putnorsky, I. 1990: "The Physical Church Thesis and Physical Computational Complexity," *Iyuuu*, Vol. 39, pp. 81–99.
- Rogers, H. 1987: *Theory of Recursive Functions and Effective Computability*, Cambridge, MA: MIT Press.
- Ross, S. 1988: *A First Course on Probability*, 3rd edition, New York: Macmillan.
- Salmon, W. 1970: *Zeno's Paradoxes*, Indianapolis: Bobbs-Merrill. Scott, S. M and Szekeres, P. 1986: "The Curzon Singularity. II," *General Relativity and Gravitation*, Vol. 18, pp. 571–83.
- Thomson, J. 1954–55: "Tasks and Super-Tasks," *Analysis* Vol. XV, pp. 1–13. Reprinted in Salmon, 1970.
- van Bendegem, J. P. 1994: "Ross' Paradox is an Impossible Super-Task," *British Journal for the Philosophy of Science*.
- Vlastos, G. 1967: "Zeno of Elea" in P. Edwards (ed.), *Encyclopedia of Philosophy*, Vol. 8, New York: MacMillan, pp. 369–79.
- Weyl, H. 1921: "Über die neue Grundlagenkrise der Mathematik," *Mathematische Zeitschrift*, Vol. 10, pp. 39–79; reprinted in *Selecta Hermann Weyl*, Basel and Stuttgart: Birkhäuser, 1956.
- Weyl H. 1927: *Philosophie der Mathematik und Naturwissenschaft*, Munich and Berlin: R. Oldenbourg.
- Weyl H. 1929: "Consistency in Mathematics," *The Rice Institute Pamphlet*, Vol. 16, pp. 245–65; reprinted in K. Chandrasekharan (ed.), *Hermann Weyl Gesammelte Abhandlungen*, Berlin: Springer, 1968.
- Weyl, H. 1932: *The Open World*, New Haven: Yale University Press.
- Weyl, H. 1949: *Philosophy of Mathematics and Natural Science*, Princeton: Princeton University Press.
- Weyl, H. 1994: *The Continuum*, New York: Dover.
- Whitrow, G. J. 1980: *Natural Philosophy of Space and Time*, 2nd edition, Oxford: Clarendon Press.
- Wisdom, J. O. 1951–52: "Achilles on a Physical Racecourse," *Analysis*, Vol. XII, pp. 67–72. Reprinted in Salmon, 1970.

PHILOSOPHERS AND THEIR CRITICS

General Editor: Ernest Lepore

Philosophy is an interactive enterprise. Much of it is carried out in dialogic as theories and ideas are presented and subsequently refined in the crucible of close scrutiny. The purpose of this series is to reconstruct this vital interplay among thinkers. Each book consists of a contemporary assessment of an important living philosopher's work. A collection of essays written by an interdisciplinary group of critics addressing the substantial theses of the philosopher's corpus opens each volume. In the last section, the philosopher responds to his or her critics, clarifies crucial points of the discussion, or updates his or her doctrines.

- 1 Dretske and his Critics
Edited by Brian McLaughlin
- 2 John Searle and his Critics
Edited by Ernest Lepore and Robert van Gulick
- 3 Meaning in Mind: Fodor and his Critics
Edited by Barry Loewer and Georges Rey
- 4 Dennett and his Critics
Edited by Bo Dahlbom
- 5 Danto and his Critics
Edited by Mark Rollins
- 6 Perspectives on Quine
Edited by Robert B. Barrett and Roger F. Gibson
- 7 The Churchlands and their Critics
Edited by Robert N. McCauley
- 8 Benacerraf and his Critics
Edited by Adam Morton and Stephen P. Stich

Benacerraf and his Critics

Edited by

Adam Morton and Stephen P. Stich