

Intersystem Operation and Mobility Management

David Tipper
Associate Professor
Graduate Program in Telecommunications and
Networking
University of Pittsburgh
Telcom 2700
Slides 6

<http://www.tele.pitt.edu/tipper.html>



First Generation Systems



- Basic Architecture AMPS, NMT, etc. similar
- Mobile telephone switching office (MisTO) connects base stations to PSTN,
- *Subscriber location and equipment databases were local to each geographical service area (CGSA) (e.g., MSA or RSA)*
- *Could only move about locally!*

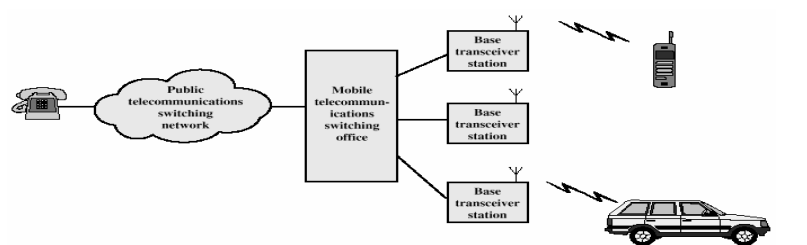

Telcom 2700

2

Intersystem Operation



Intersystem operation problem

- How to support handoffs and roaming between CGSA's within a operator's network or between different operator's networks if a roaming agreement in place and they support the same air interface

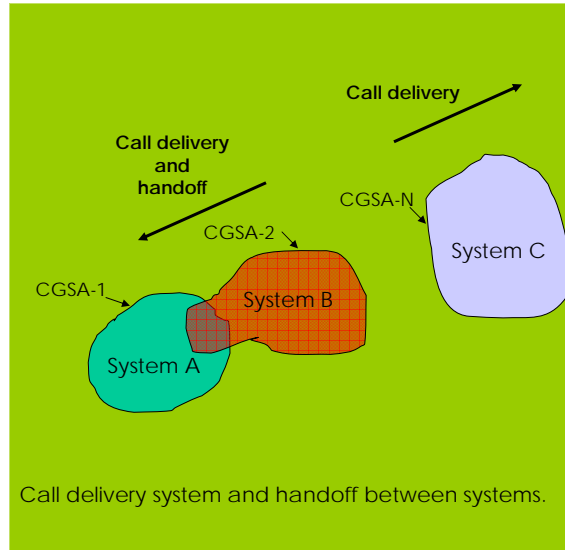

Telcom 2700

3

Intersystem Operation



- First Generation Systems: AMPS, NMT, etc.
 - Limited interoperability
 - AMPS service provider could not handoff calls between their own CGSA's or support roaming between them
 - No roaming across systems of the same type but of different service providers
 - Why?
 - Legal hurdles, billing problems, propriety systems in the backhaul as 1G standards are air interface standard only, basically didn't think it would be needed
- Initial Intersystem Operation Solutions (ad-hoc in nature)
 - Manual – through a clearing house – required phone ahead scheduling
 - Follow Me Roaming – GTE system - automated clearing house approach

Telcom 2700

4

Clearing House Based Roaming

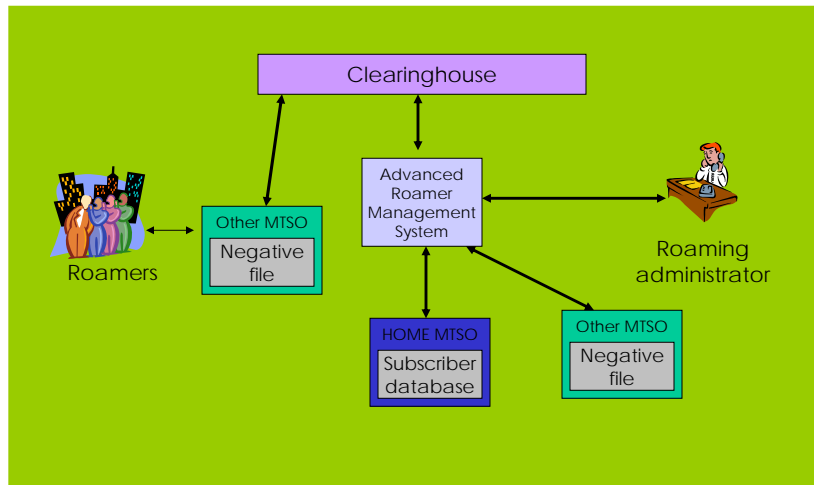

Telcom 2700

5

Intersystem Operation Follow Me Roaming

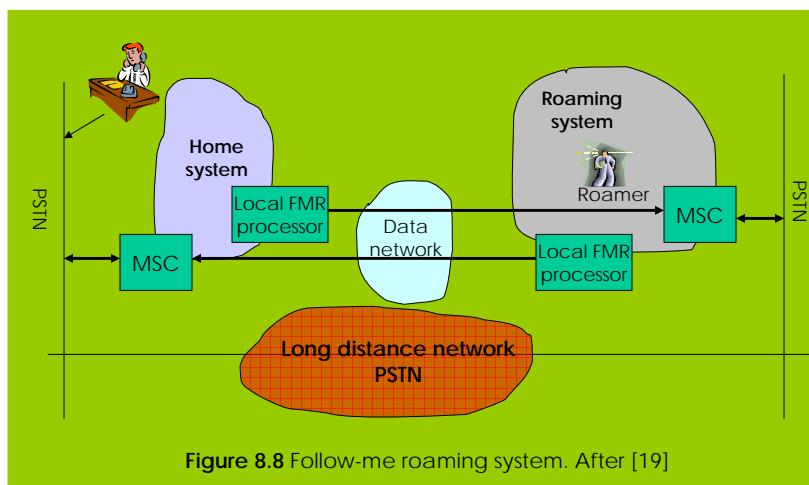

Figure 8.8 Follow-me roaming system. After [19]

Telcom 2700

6



Mobility Management



- **Mobility Management Problems**
 1. **Location Management**
 - Track location of users for incoming calls within a CGSA and allowing user to roam between CGSA service areas of a service provider while having the ability to place/receive calls, also support roaming among different service providers supporting the same air interface standard
 - Location registration/authentication/paging
 2. **Handoff Management**
 - Maintain in progress connection as user moves
 - (Handoff/rerouting) within systems, between systems

Mobility Management



- **Mobility Management Standards**
 - IS-41 (several revs: IS-95, IS-54, AMPS)
 - GSM-MAP (Mobile Application Part)
 - ITU-T (E.750 series)

Location Management

Handoff Management

- GSM standard developed first, then IS-41,
- ITU –T: specifies performance standards
- All three are based on a system architecture

Basic PCS Architecture

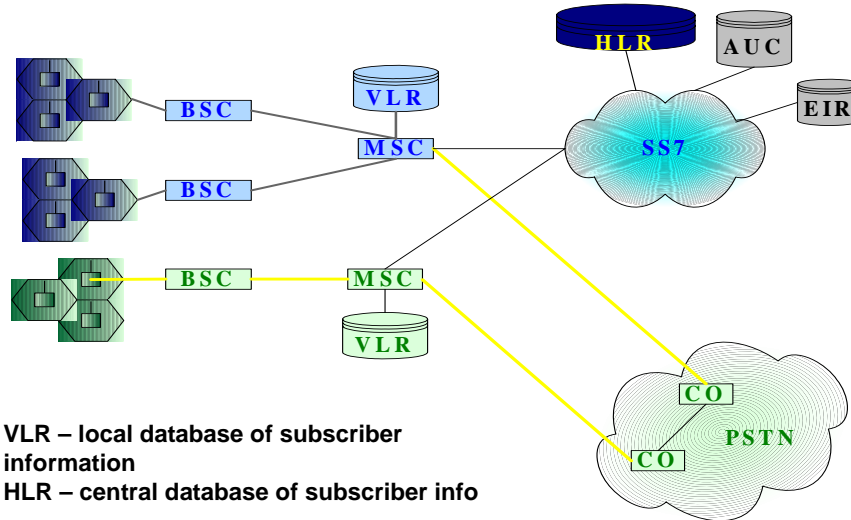

VLR – local database of subscriber information
HLR – central database of subscriber info

Telcom 2700

9

IS-41 Architecture Reference

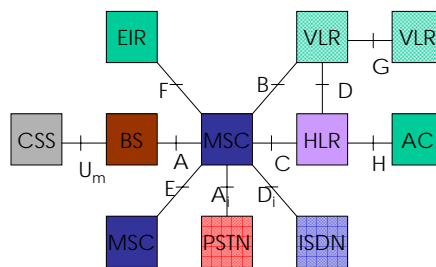

AC: authentication center HLR: home location register
BS: base station ISDN: integrated services digital network
CSS: cellular subscriber station (terminal) MSC: mobile switching center (MTSO)
EIR: equipment identity register PSTN: public switched telephone network
VLR: visitor location register

Telcom 2700

10

GSM System Architecture

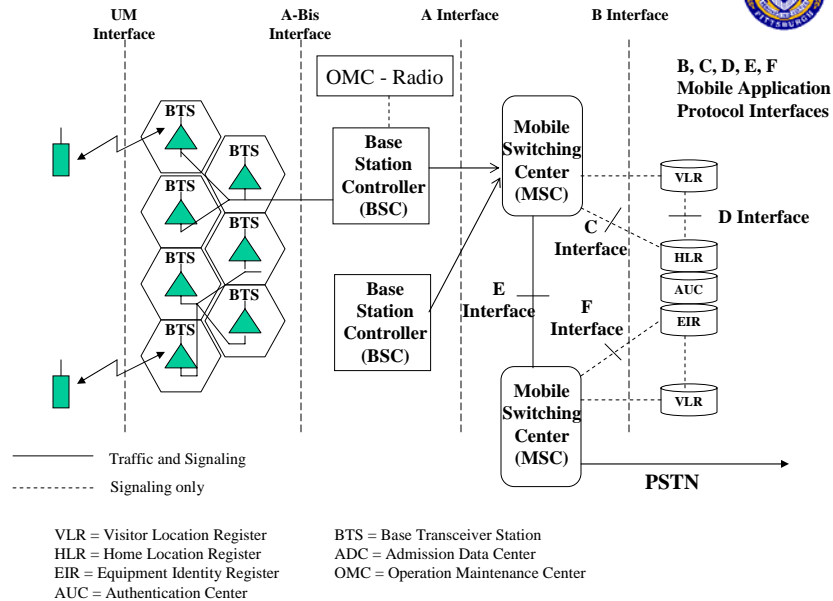

Telcom 2700

11

Location Management



- **Location Area (LA)**
 - Divide coverage into non-overlapping groups of cells
 - Assign each LA a unique id
 - Location Area ID is periodically broadcast by each cell
 - As a mobile moves/turns phone on – it listens to location area id – depending on the approach – it may perform a location update/authentication procedure to provide it's location to VLR and possibly HLR
- **Two level database hierarchy HLR/VLR**
 - HLR points to VLR where mobile located
 - VLR entry points to LA where mobile last located
- **In large networks may have HLR split among regions with aggregate info cross region**

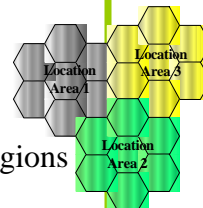

Telcom 2700

12

Location Area and Cell Identification Parameter



MNC – Mobile Network Code

Identifies the GSM operator within the country. In AMPS system the network code is the system ID (SID)

LAC – Location Area Code

Defines a location area, which consists of a group of cells. Each MNC will have several LACs.

CI – Cell Identity

Uniquely identifies a cell in a location area.

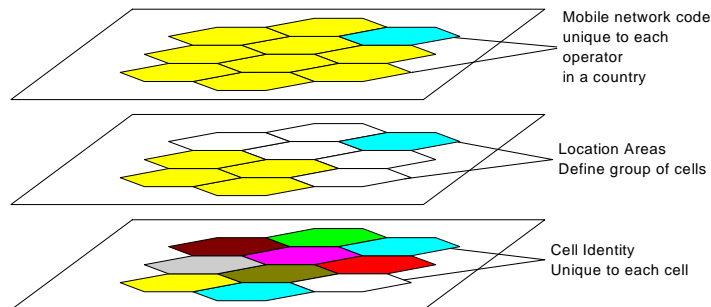

Telcom 2700

13

Location Management



- Location Management involves two main tasks to support mobile receiving incoming calls and roaming
- Location Registration/update
 - Mobile informs network of location using reverse control channels
 - May include an authentication step here as well
- Paging
 - Network informs mobile of incoming call
 - Broadcast over group of cells (paging area) on forward control channels
- Tradeoff: registration/updating and paging

Telcom 2700

14

Location Registration



- Location Registration involves signaling to VLR and possible HLR
- Two Types of Location Registration
 1. Intra – VLR (LAs attached to same VLR)
 - Only change LA id in VLR (local signaling)
 - Target ITU-T location update time ≤ 2 sec
 2. Inter –VLR (LAs attached to different VLR)
 - must signal HLR to update VLR pointer
 - Target ITU-T Location update time ≤ 4 sec

Telcom 2700

15

Inter-VLR Location Update



- Walkthrough Inter-VLR case
 1. Mobile powers up scans reverse control channels, locks on to strongest signal. Listens to forward broadcast control channel until Location Area ID heard
 2. Since Location Area ID - differs from last one mobile registered in mobile signals on reverse control channel to serving MSC, MSC signals HLR update VLR pointer
 3. AUC verifies user- may issue challenge/response authentication procedure
 4. HLR – gives VLR mobile service profile
 5. HLR – deregisters mobile from last VLR locationTarget ITU-T bound on location registration ≤ 4 sec

Telcom 2700

16

Inter VLR Location Update Call Flow

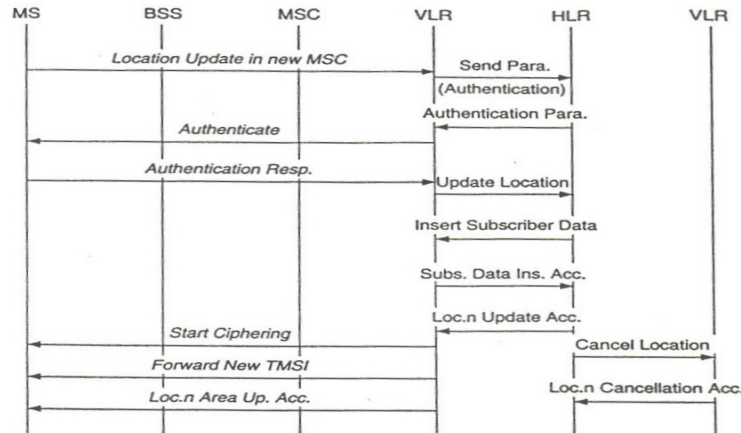
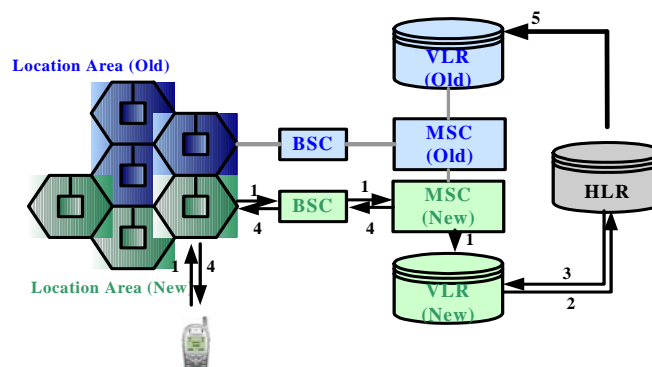

Figure 6.20 Location update call flow: only MS, VLR, and HLR interactions are shown.

Telcom 2700

17

Inter-VLR Location update in GSM



1. The MS sends the Location Update request to the VLR (new) via the BSS and MSC.
2. The VLR sends a Location Update message to the HLR serving the MS which includes the address of the VLR (new) and the IMSI of the MS. This updating of the HLR is not required if the new LA is served by the same VLR as the old LA.
3. The service and security related data for the MS is downloaded to the new VLR.
4. The MS is sent an acknowledgement of successful location update.
5. The HRL requests the old VLR to delete data relating to the relocated MS.

Telcom 2700

18

Location Management



- Location Update Techniques in practice
 - Timer based periodic registration (AMPS)
 - LA crossing based (cell broadcast LA id)
 - NA-TDMA, IS-95, GSM, 3G systems
 - Hybrid LA crossing + timer based (GSM)
 - Distance Based (IS-95)
- Paging Techniques
 - Paging Area (PA) usually same as LA but doesn't have to be
 - Blanket polling commonly deployed (page all cells simultaneously)
 - If no response after a fixed number of attempts – give up and roll over to voice mailbox
 - Target ITU-bound on paging delay time = 4 sec

Mobile Terminated Call Example



- Assume a mobile has registered its location with VLR and HLR
- 1: calling a mobile subscriber
- 2: forwarding call to GMSC
- 3: signal call setup to HLR
- 4, 5: request status from VLR
- 6: forward responsible MSC to GMSC
- 7: forward call to serving MSC
- 8, 9: get current status and LAI of MS
- 10, 11: **Paging of MS**
- 12, 13: MS answers
- 14, 15: security checks
- 16, 17: set up connection

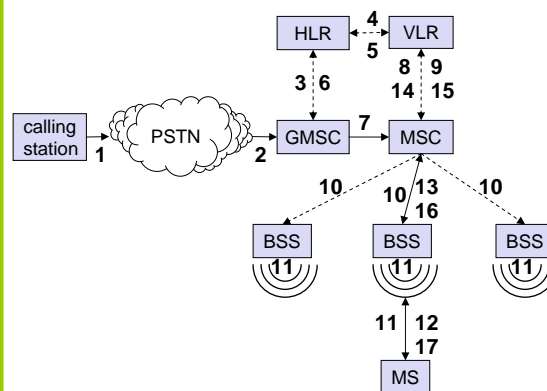

Tradeoff between Location Update and Paging

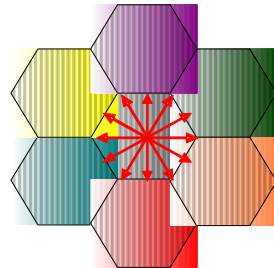

1 cell = 1 location area
Frequent location updates and
a minimal paging in a cell

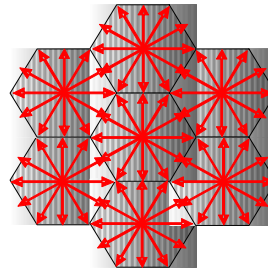

whole service area (SA) = 1 location area
No location updates in SA and
a large number of pages

Telcom 2700

21

Tradeoff between LU and Paging



- Obviously must balance location update traffic load and paging load to minimize overhead to the network and battery drain on mobile

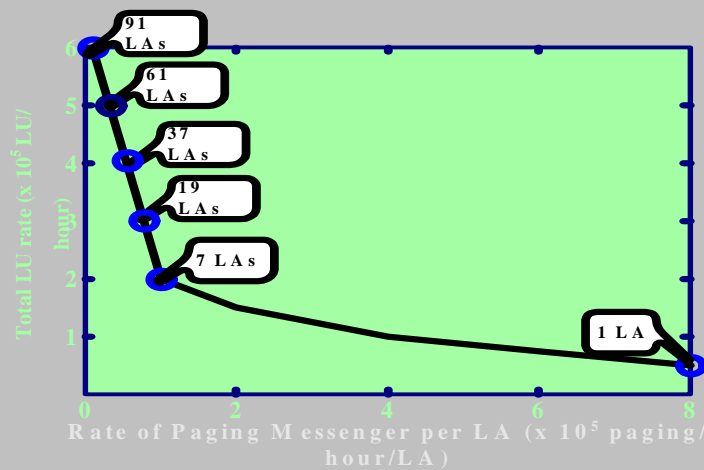

Telcom 2700

22

Paging Techniques



- Paging aims to quickly locate the mobile users to be able to deliver the call within a time constraint.
- Interesting question
 - What is the optimal size of the paging area?
 - What is the tolerance delay for the network?
(4 seconds suggested by ITU)
- Paging Techniques:
 - Simultaneous (Blanket Polling)
 - Sequential (Selective Paging, Intelligent Paging)

Paging Techniques



- Sequential Paging
 - Selective Paging
 - Page small group of cells around last registered location
 - (VLR keeps track of cell + LA)
 - No response then page the rest of LA
 - Intelligent Paging
 - The network determines the paging strategy
 - If the current traffic load is lower than a certain threshold, send a blanking polling.
 - Otherwise use some sort of selective paging

Handoff Management



- Call in progress Mobility management
- Radio Mobility (Handoff or Handover) (BSC or MSC)
 - Based on air interface standard
 - Hard Handoff (break before make)
 - Soft Handoff (make before break)
 - Mobile Assisted Handoff (MAHO)
- Handoff measurement: major decision-making stages
 - Identify the need
 - Identify the candidate
 - Evaluate the candidates
 - Select a target cell

RSS (received signal strength) base



- RSS is the direct indication of actual received energy at the mobile
- Controlled parameters: threshold level, hysteresis margin H and averaging interval

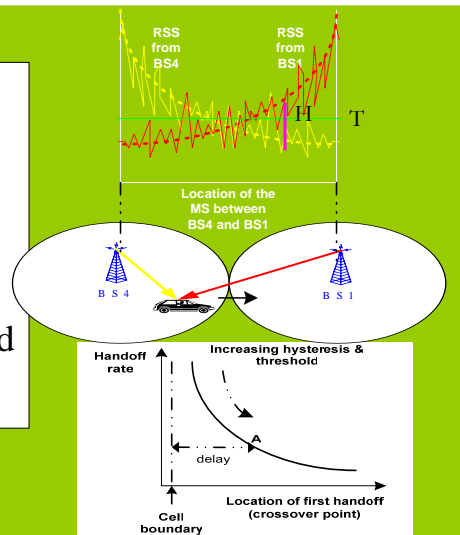

Handoff Management



- Two categories of handoff
 - Intrasystem handoff (3 cases)
 - Intracell handoff (different sector of same cell)
 - Standard Handoff (cells attached to same BSC)
 - Inter BSC handoff (same MSC)
 - Intersystem handoff
 - Cells attached to two different MSCs
 - Require specialized signaling
 - IS-41, GSM -MAP protocol
 - Three cases
 - A. Handoff Forward
 - B. Handoff Back
 - C. Handoff to a Third

Telcom 2700

37

Types of Handoff

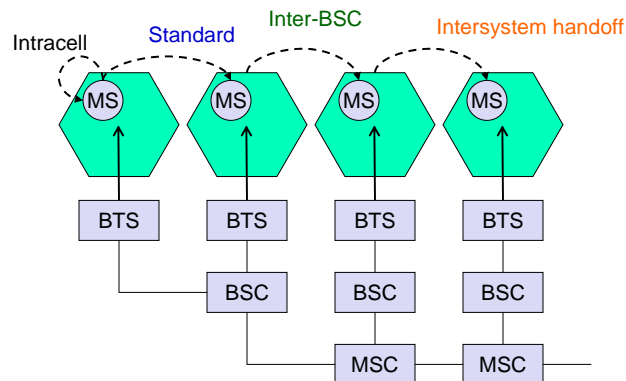

Telcom 2700

38

Intersystem Handoff – Handoff Forward

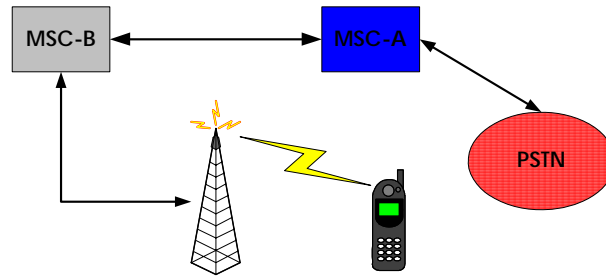

The situation after a handoff forward from System A (anchor system) to System B (serving system).

Telcom 2700

39

Handoff Forward



Table 4.2 MSC Status Before, During, and After a Handoff Procedure

	Anchor	Serving	Candidate	Target
Call begins	MSC-A	MSC-A		
Terminal approaches service area of MSC-B	MSC-A	MSC-A	MSC-B	
MSC-A decides to transfer call to MSC-B	MSC-A	MSC-A		MSC-B
Handoff complete	MSC-A	MSC-B		

Telcom 2700

40

Handoff Forward



Goodman Figure 4.11 IS-41 Message sequence and system operations for handoff forward.

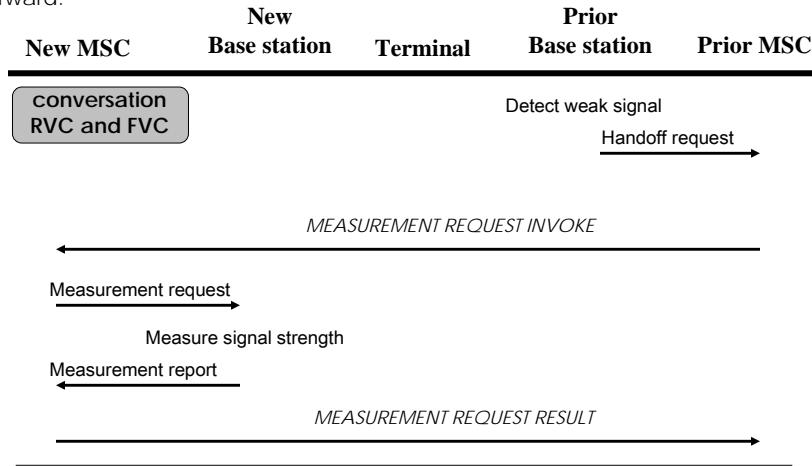

Telcom 2700

41

Handoff Forward

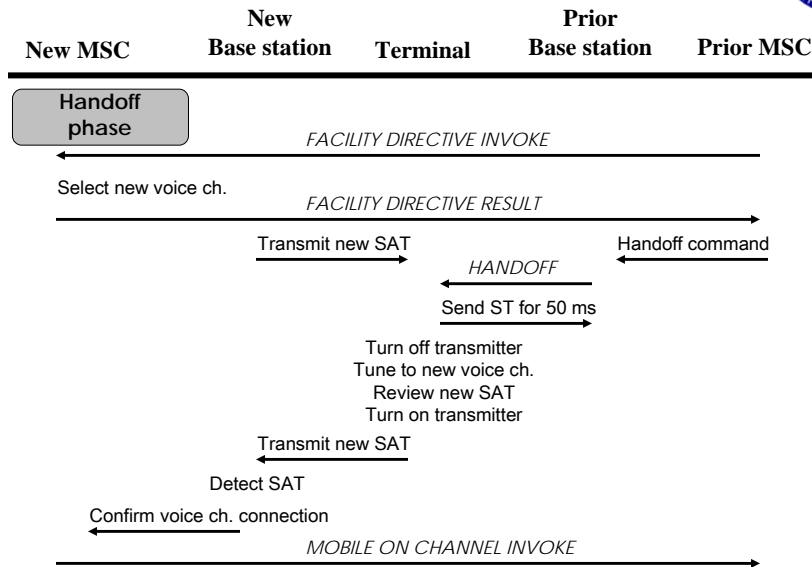

Telcom 2700

42



Handoff Back

After a Handoff Forward From MSC1 to MSC2 User may move back to a cell attached to anchor MSC 1– use *HANDOFF BACK* command to prevent call going from MSC1 to MSC2 back to MSC1 in wired network Called the shoelace effect

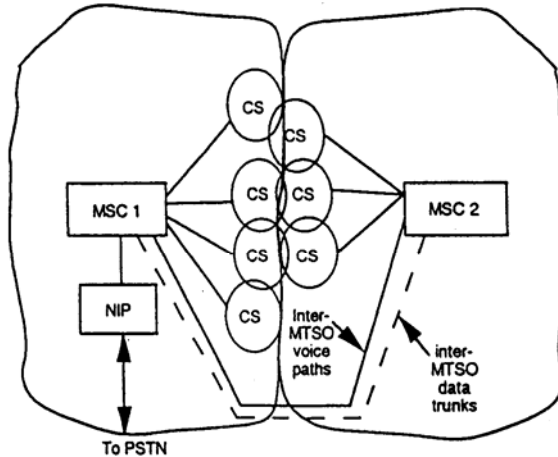
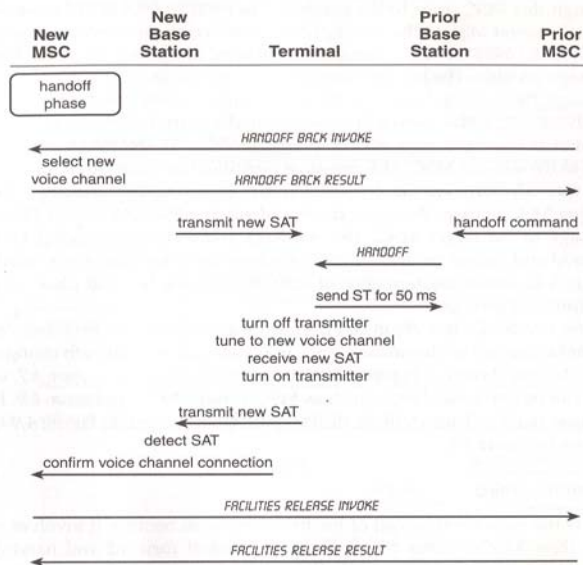

Figure 8.3 Call delivery and intersystem handoff between two adjacent systems. After [1].



Handoff Back

Handoff Back signalling in IS-41





Trombone Effect

As user moves route several handoff Forwards can occur resulting in non optimal routing in wired network part - called the *Trombone Effect*

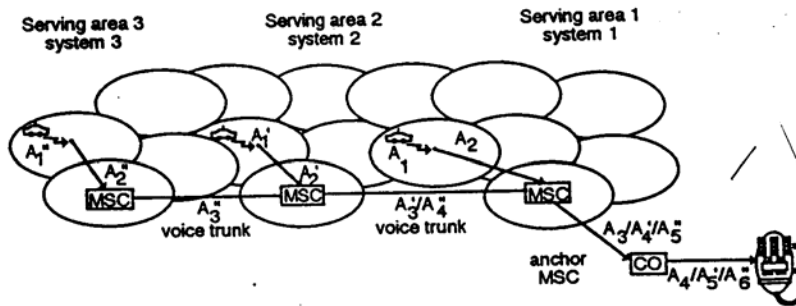

Trombone Effect

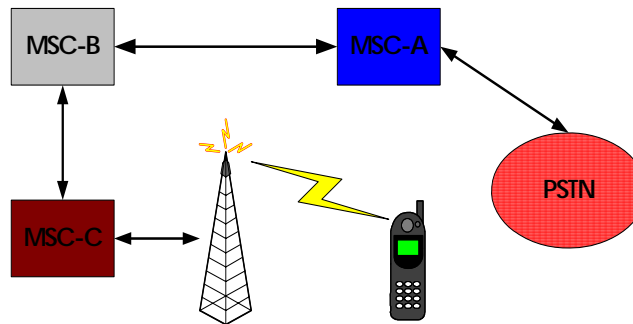

Simple Case of two Handoff Forwards – results in the call path shown above after handoff forward to System C.
Current Solution is HANDOFF to a THIRD command

Handoff to a Third

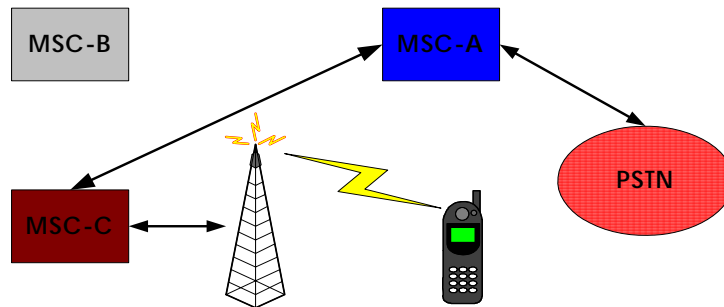

- If there are circuits connecting MSC-A and MSC-C, the system can perform handoff to third with this result.
- Yields better routes in wired network

Telcom 2700

47

Handoff to a Third



Handoff to a third signalling in IS-41

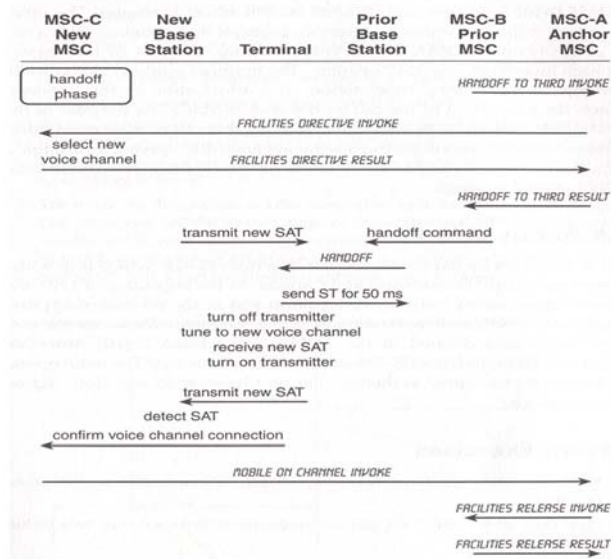

Telcom 2700

48